

LIGHTING COLLECTION



HAY



Content

Overview

Cupola

Drome

Ono

Apex

Brim

Mousqueton

Parade

LBM

Anagram

Apollo

Factor Linear

Paper Cube

Common

Arcs

Slant

Pao

Matin

HAY x Liberty Matin

PC

Bonbon

Nelson Bubble

Fifty-Fifty

Marselis

Turn On

Noc

Cloche

30 Degrees

Dimensions



HAY Lighting

HAY's Lighting collection is an extensive selection of carefully curated designs that offer durable and innovative lighting solutions by some of the world's best contemporary designers. In our endeavour to create longer lasting and more energy-efficient lights, we mainly use LED light sources and strive to match affordability with functionality and originality.

HAY Lighting covers a diverse range of needs and environments, offering versatile options that can be integrated into domestic, professional, and public settings.

Ceiling Lamps

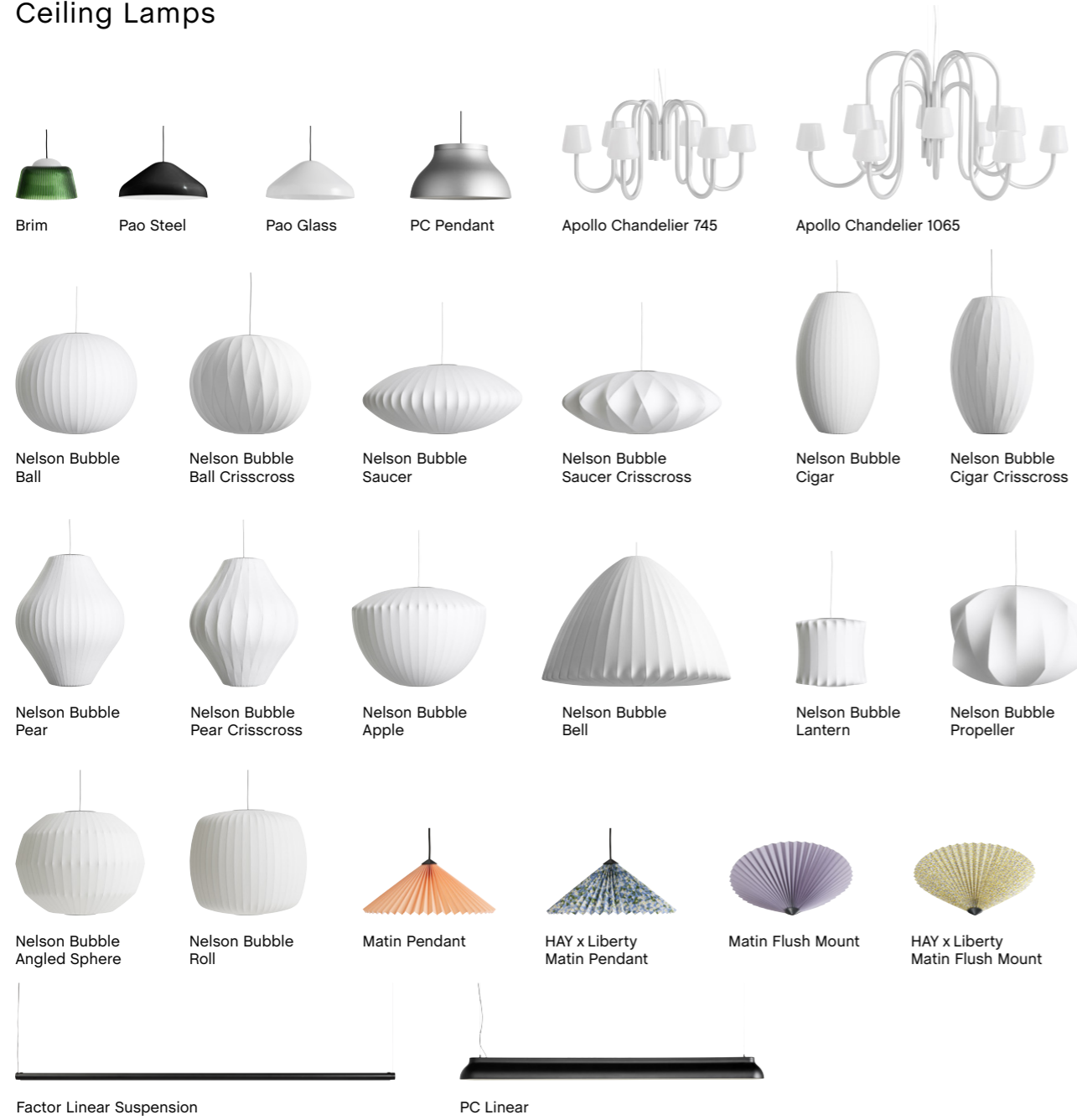
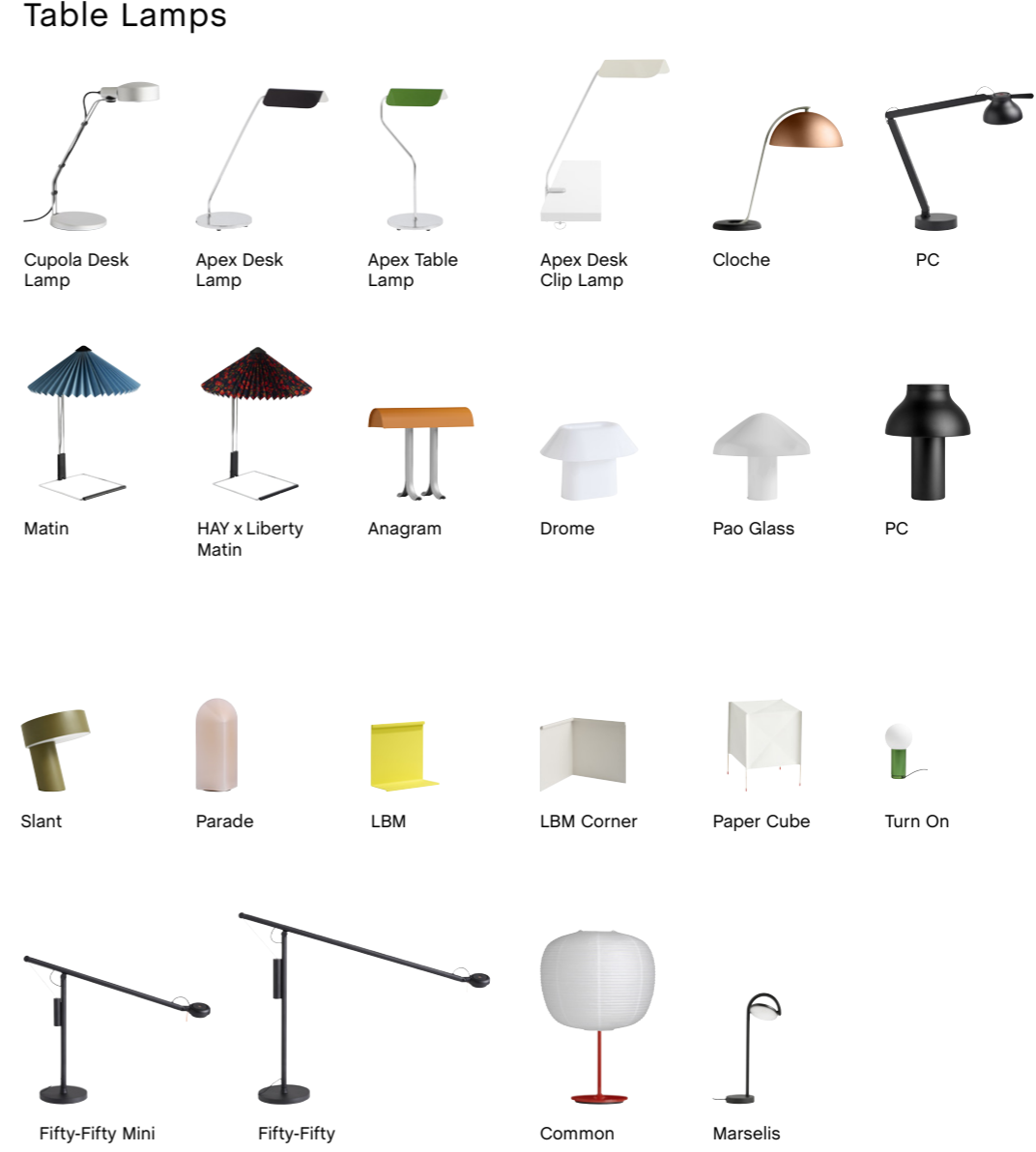

Table Lamps



Lamp Shades



Portable Lamps



Clip Lamps



Cupola Clip Lamp

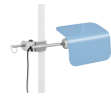

Apex



Noc Clip

Wall Lamps



Arcs Switch



Arcs Sconce

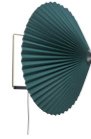

Matin



HAY x Liberty Matin



Noc Wall



Noc Wall Button



Nelson Ball Sconce



Nelson Cigar Sconce



Nelson Pear Sconce



Nelson Saucer Sconce



Apollo Wall Sconce Lamp



Ono Flush Mount 200



Ono Flush Mount 350



Cupola Wall Lamp

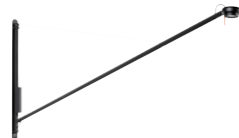

Fifty-Fifty



PC

Floor Lamps



Common



Matin



Pao Steel

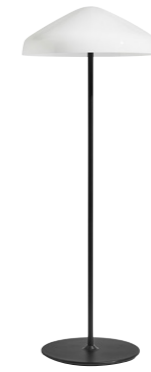

Pao Glass



Marselis



Fifty-Fifty



Paper Cube

Cord Sets



Common Pendant Cord Set



Common Table Cord Set

Cupola Design by John Tree

Cupola is a collection of adjustable lamps that explores the possibilities of providing optimal movement using minimal mechanisms. All the lamp designs feature circular domed heads that are distinctive in their simplicity, while offering a highly technical lighting solution. Crafted in durable aluminium with a natural anodised finish, the lamps balance a raw, industrial expression with rounded forms. Available as a Clip Lamp, Desk Lamp, and Wall Lamp, all equipped with a 360° rotating head and pivoting mount to provide localised, directional light to suit specific uses and rooms.



John Tree

John Tree is a London-based product and furniture designer. He divides his time between Jasper's Morrison's studio and his own, where he pushes and explores industrial processes to create contract and domestic furniture, lighting, accessories, and electronics. For HAY, John Tree has also designed the Apex Lamp collection.



Cupola Lamp family

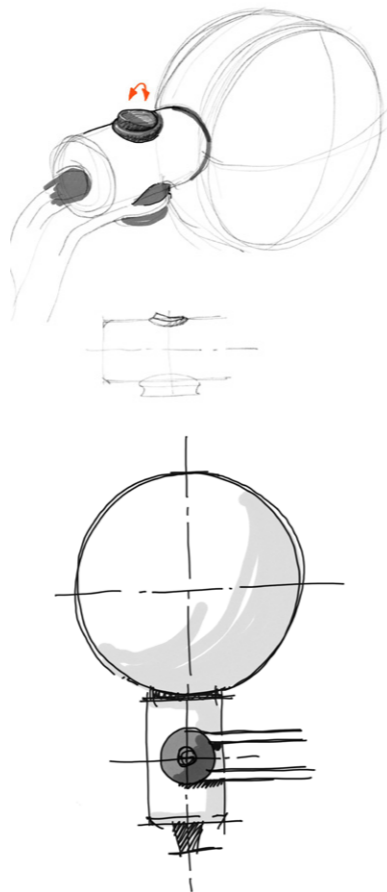
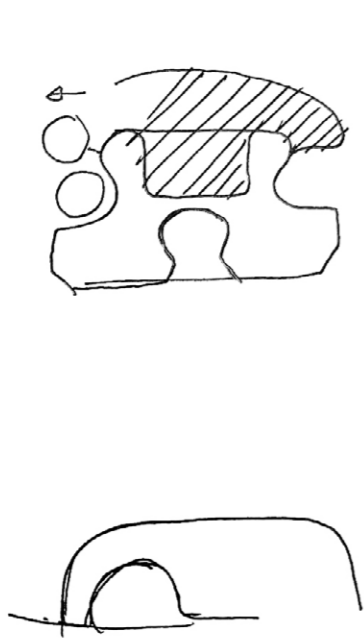
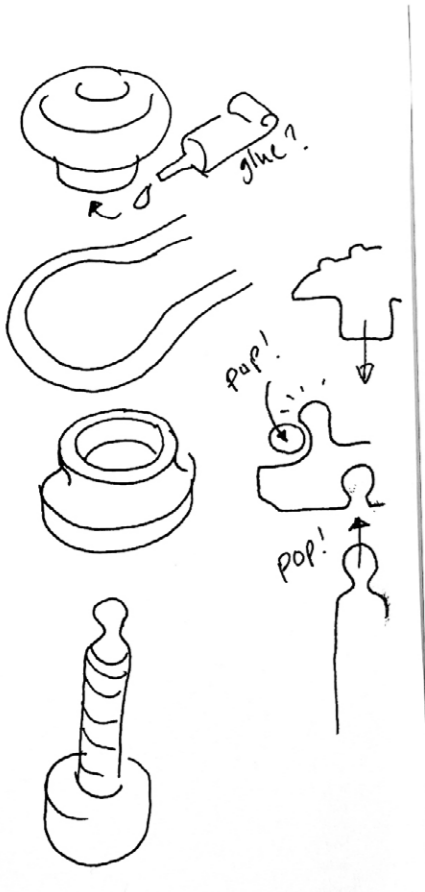
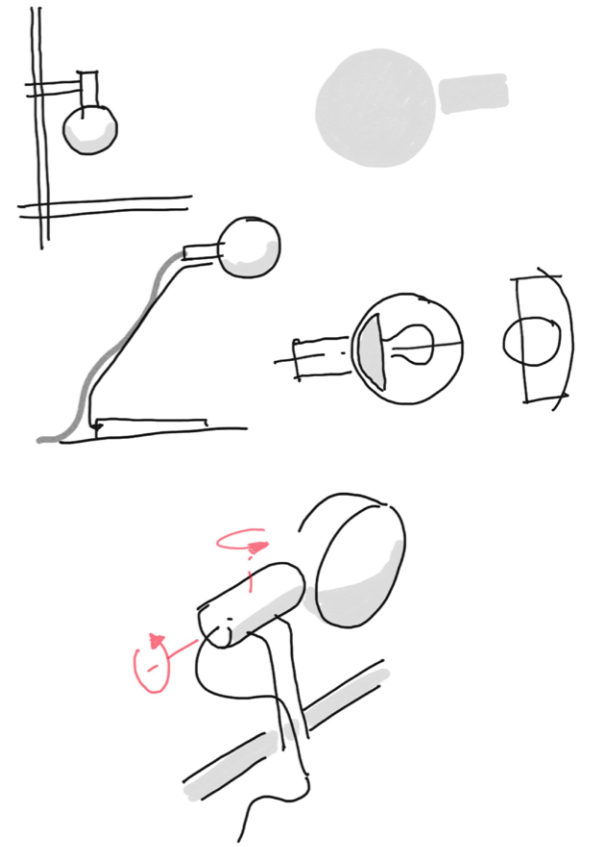
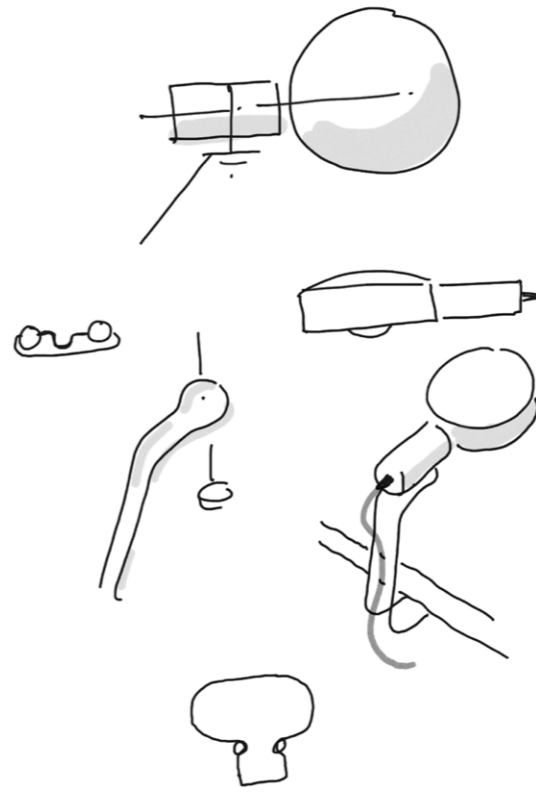
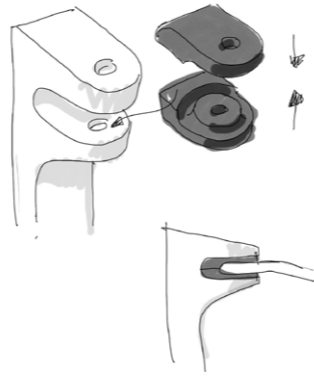



Cupola Desk Lamp



Cupola Clip Lamp



Cupola Lamp family



Cupola Desk Lamp

Drome

Design by Christian Juhl

Drome is a versatile table lamp defined by its distinctive oval shape. The lamp's stretched elliptical form changes the perception of the lamp, depending on which angle it is viewed from. Concealed inside the hollow form is a replaceable integrated light source, creating a unified, minimalistic silhouette that enables light to glow through it. The inline step dimmer allows the light output to be adjusted, making the lamp a versatile light source that can be used to create atmosphere in a variety of environments and settings, from a bedside table or desk to a windowsill or bookshelf.



Christian Juhl is a Danish product and furniture designer based in Copenhagen. Using an explorative approach to materials, crafts, and joinery, he aims to create contemporary and long-lasting design solutions.





Concealed inside the hollow form is a replaceable integrated LED light source that brings soft, ambient light to its surroundings.



The lamp's stretched elliptical form changes the perception of the lamp, depending on which angle it is viewed from.





Ono

Design by Aspekt Office

Designed for HAY by Aspekt Office, Ono Flush Mount is a functional and uncluttered lamp with strong, simple aesthetics. Designed with optimal versatility and minimal details in mind, the lamp's clean, symmetrical lines create a graphic expression. The centrally located light source is surrounded by the conical shade, creating a halo effect that diffuses a warm, welcoming light. Its neutral yet characterful design enables Ono Flush Mount to be used on walls and ceilings in many different rooms and environments, including bathrooms, porches, and other partially covered outdoor spaces. Available in two different sizes.



Aspekt Office

Based in Copenhagen, Aspekt Office is a design studio, specialising in furniture, product, interior design and creative direction. Founded in 2018 by Hans Toft Hornemann and Terkel Skou Steffensen, the designer duo uses conceptual thinking and original ideas in their intuitive approach to design.





Designed with minimal details in mind, the lamp's clean, symmetrical lines create a graphic expression.



Drawings and proto samples of Ono Flush Mount.



Ono Flush Mount 350

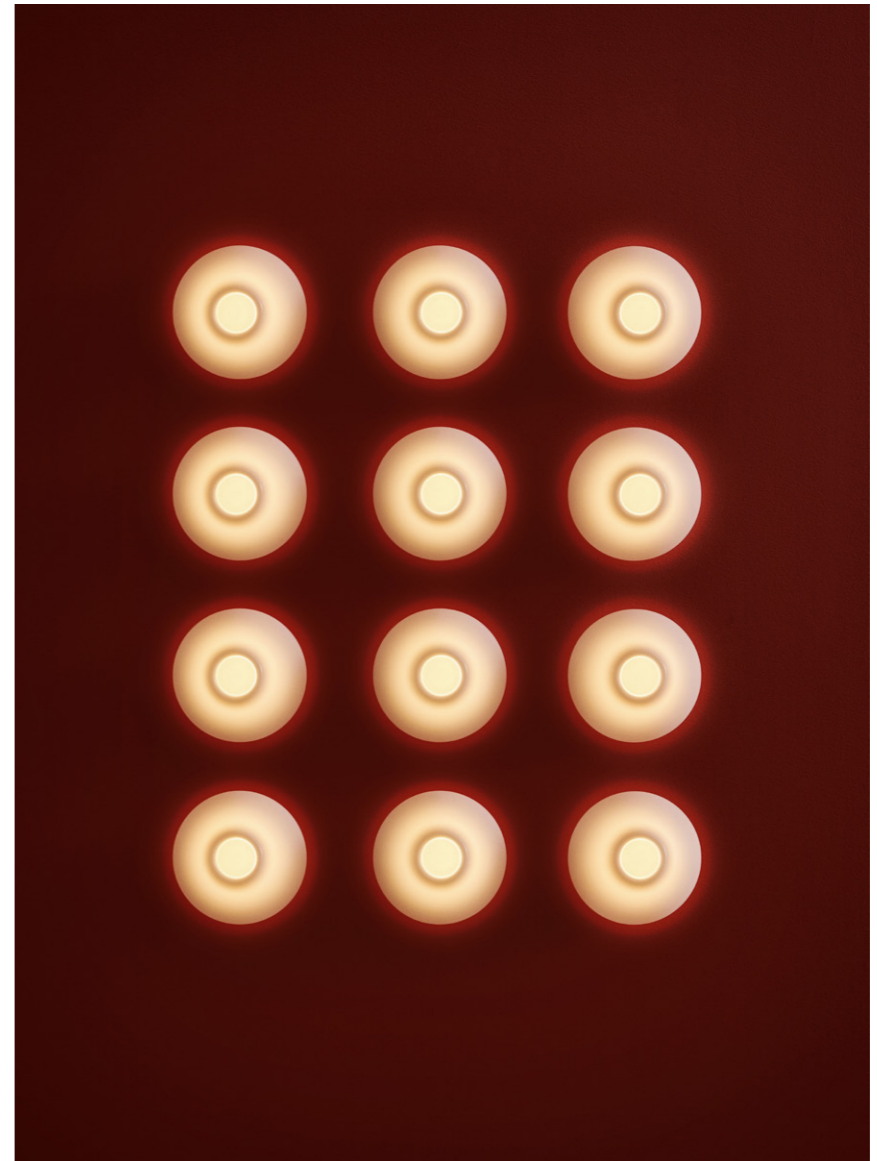

Ono Flush Mount 200

Apex Design by John Tree

In HAY's new collaboration with John Tree, the British designer offers his take on the classic Banker's Light typology, resulting in a functional lamp series that balances familiarity with a contemporary expression.

Focusing on colour as a core element of the design, Apex's distinctive folded steel shade uses vibrant tones to create a graphic contrast to the chrome-plated bases. Available in several different models – the Clip Lamp, Desk Clip Lamp, Desk Lamp, and Table Lamp – there is an Apex member that caters to every space and situation, from a task light in a workspace to an ambient lamp in the bedroom.



John Tree



Apex Lamp family

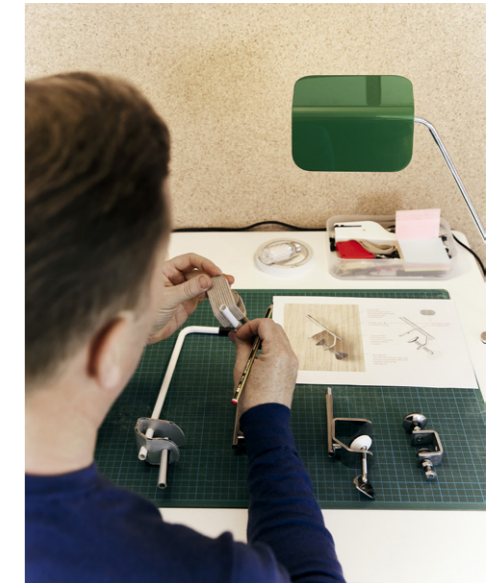

Colour is used as a key element in the folded steel shades, creating strong and colourful graphic shapes.



Apex Clip Lamp | Luis pink



Folded steel shades

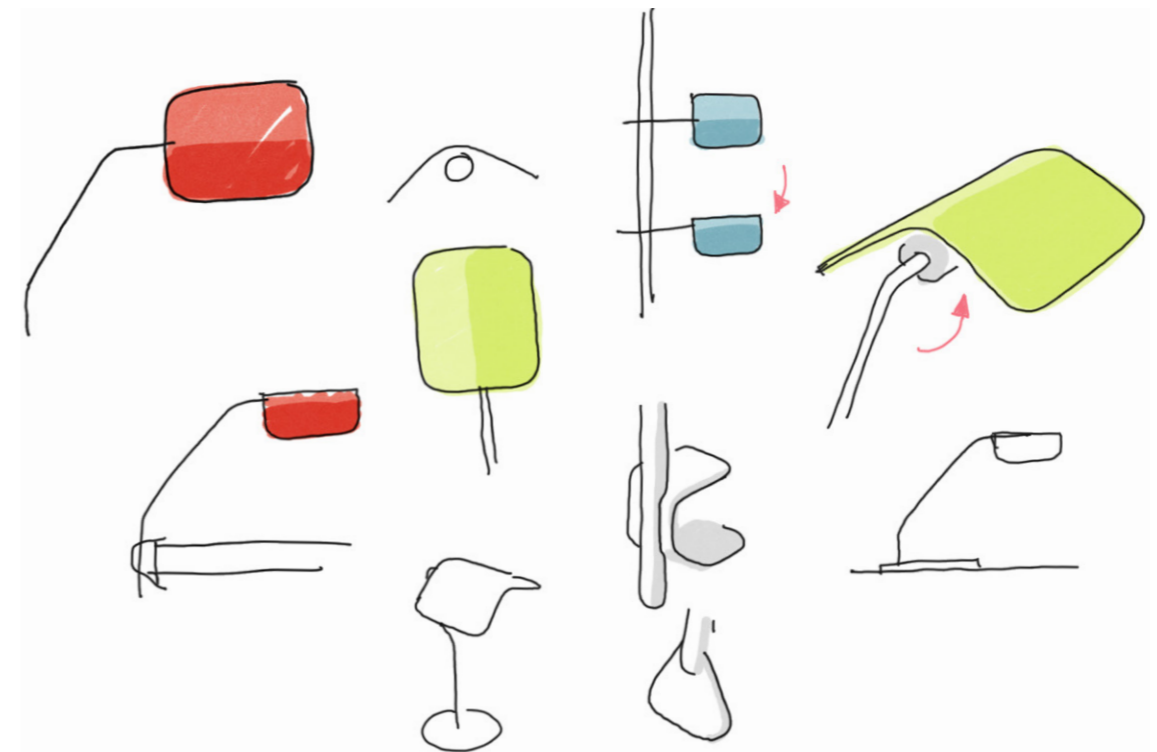

The shade is designed to rotate 360 degrees, offering a flexible lighting solution that covers a multitude of spaces and uses.



Apex Desk Clip Lamp | Iron black



Apex Clip Lamp | Maroon red

Brim

Design by Rui Pereira & Ryosuke Fukusada

Brim is an ambient pendant with a coloured pressed glass shade, inspired by classic glass pendants from past times. The familiar light typology has been updated in new materials and construction to optimise the function whilst retaining the pendant's timeless aesthetics. The internal sphere conceals the bulbs, which is surrounded by a distinctive fluted glass shade that enhances the light diffusion. Brim's compact size makes it ideal for hanging in clusters, as well as on its own in smaller spaces such as in hallways or over counters.

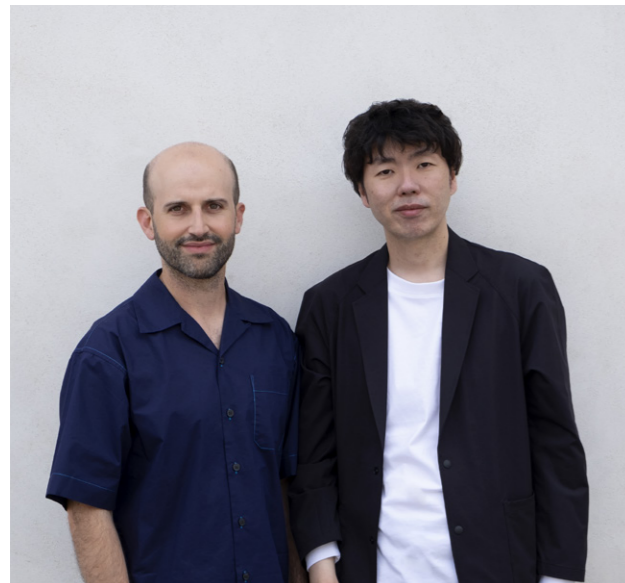

Portuguese designer Rui Pereira and Japanese designer Ryosuke Fukusada collaborate on projects that tap into their respective cultures to engage users in new and unsuspected design experiences.



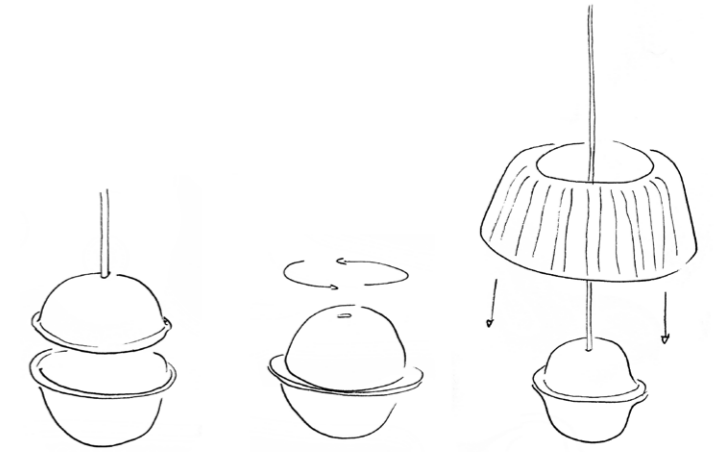
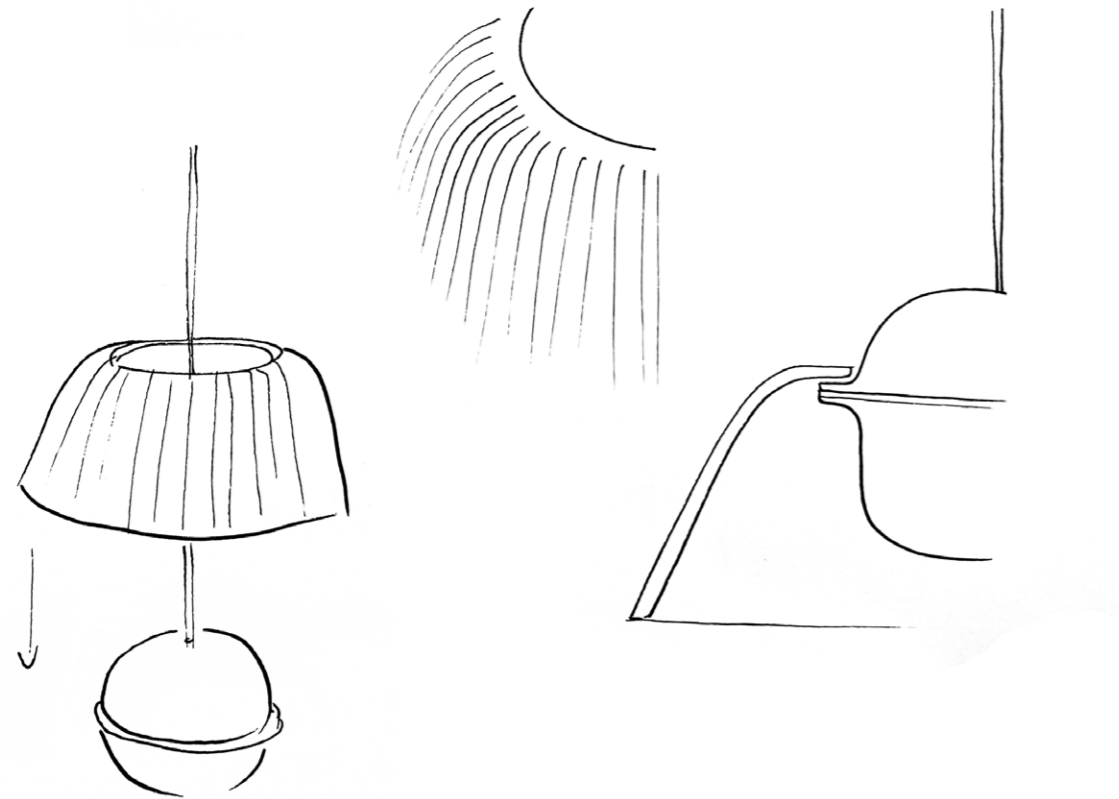
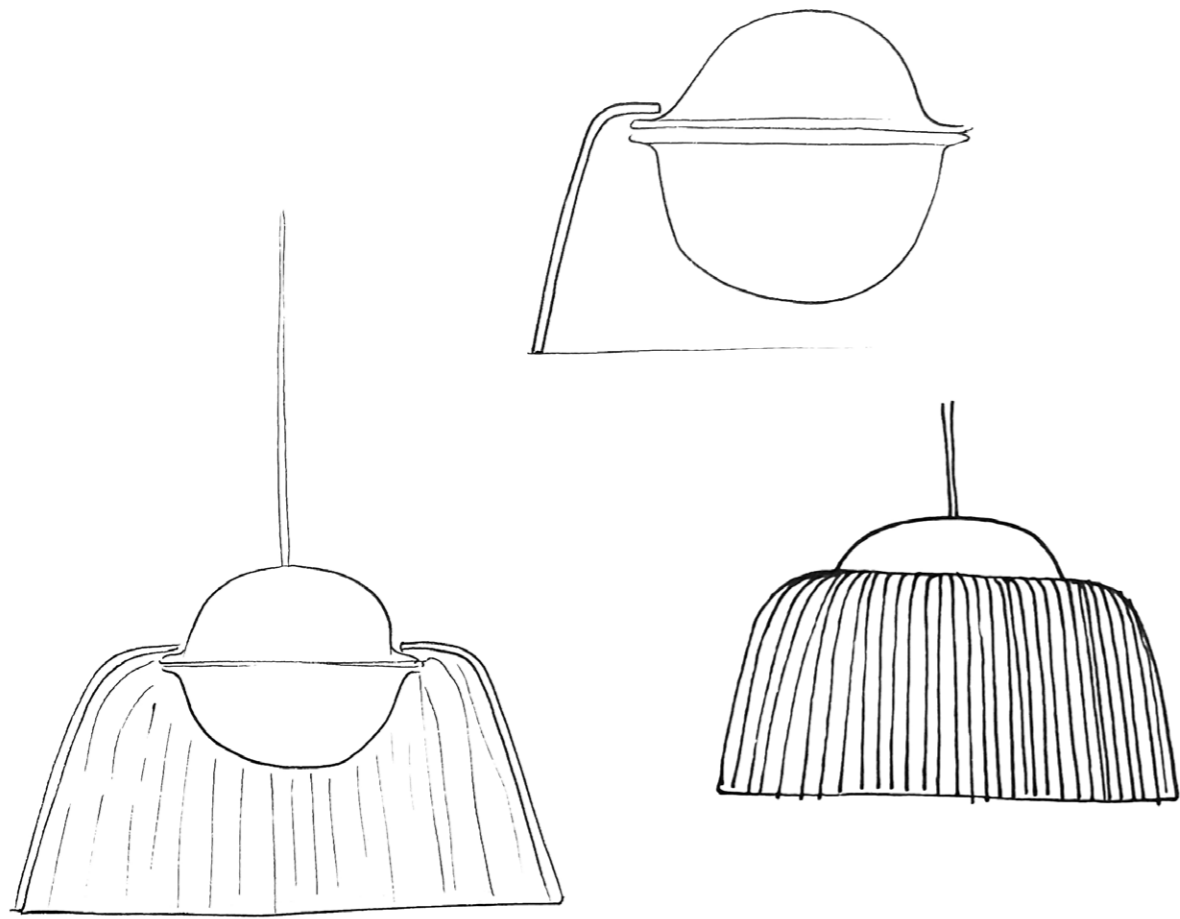



Brim Pendant 245 | Smoked grey glass



Brim Pendant 245 | Clear glass



Brim Pendant 245 | Bottle green glass

Mousqueton

Design by Inga Sempé

Named after the French word for carabiner, Inga Sempé's Mousqueton Portable Lamp is an outdoor LED lamp that presents a functional lighting solution with a familiar yet contemporary aesthetic. Featuring a multi-purpose hook at the top that creates multiple hanging possibilities, as well as a central hole detail, the lamp cleverly integrates technical features to amplify the functional and decorative qualities. With its solid construction and original design, Mousqueton Portable Lamp brings ambience to spontaneous and happy moments in both indoor and outdoor settings.



Inga Sempé is a French designer who lives and works in Paris. Her work is known for a lightness of touch, for a strong personality and for a particularly tactile nature.



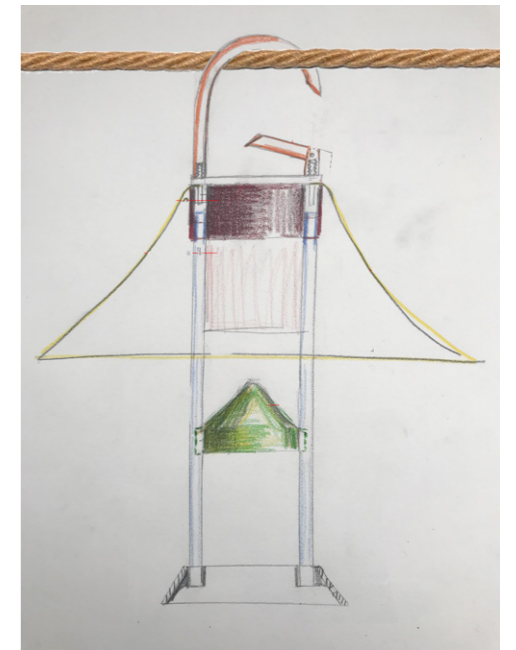

The design makes use of the multi-purpose hook to create multiple hanging possibilities, enabling the lamp to be suspended over a branch, rope or other protruding elements.



Inga Sempé's drawings of Mousqueton



Mousqueton Portable Lamp | Oyster white

Parade

Design by Viola Heyn-Johnsen and Jonas Trampedach

Designed by Danish husband-and-wife designers Viola Heyn-Johnsen and Jonas Trampedach, the Parade Table Lamp series was inspired by the desire to create an ambient light source with a sculptural quality. The name refers to the lamp's ability to command attention when several lamps are positioned together like a formation in a parade, where the square lines fit can fit together in a tessellated pattern.

The glass geometric shape is made in carefully selected sizes and colours, designed to complement each other in height, tone and temperature and thereby creating a cohesive effect. Equally appealing switched on or off, as a stand-alone lamp or displayed as a group of light sculptures, Parade combines functionality with aesthetics to create a unique and atmospheric lamp.



Viola Heyn-Johnsen and Jonas Trampedach are a husband-and-wife team with a shared passion for materials, objects and craftsmanship. Their design studio focuses on products, furniture and lighting.





Viola and Jonas were inspired by the desire to create an ambient light source with a sculptural quality.

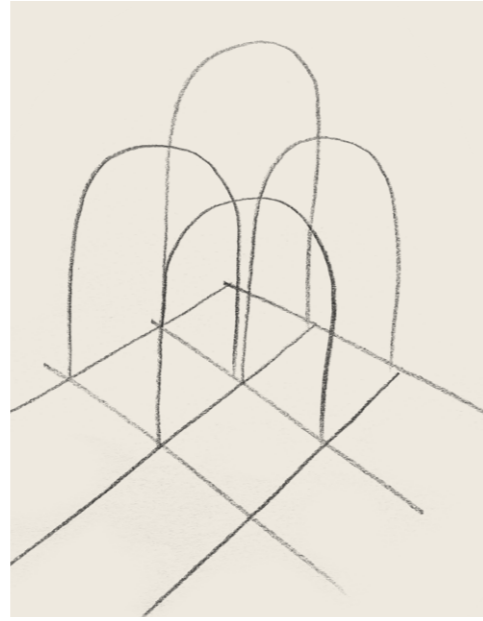

The name refers to the lamp's ability to command attention when several lamps are positioned together like a formation in a parade.



The glass geometric shape is made in carefully selected sizes and colours, designed to complement each other.



Parade Table Lamp 240 | Moss green



Parade Table Lamp 320 | Shell white
Parade Table Lamp 160 | Blush pink

LBM

Design by Moisés Hernández

Inspired by compatriot Luis Barragán Morfín, Moisés Hernández's LBM Table Lamp and Corner Table Lamp are influenced by the Mexican architect's innovative use of geometry, colour, and light.

The LBM lamps feature one or two folded vertical planes of sheet steel to create a similar poetic interplay of light and colour. The lamps' unique, calming atmosphere create an artistic quality that is equally appealing both when in use and switched off. The LBM series' functionality and deliberately uncluttered design makes it suitable for a wide range of spaces and uses in domestic and corporate environments.



Moisés Hernández is a Mexican designer working from his studio in Mexico City. In his work, Moisés seeks to use very simple shapes that he complements with colour and texture to bring warmth to the everyday objects that he designs.





LBM uses folded vertical sheet steel to create a poetic interplay of light and colour.

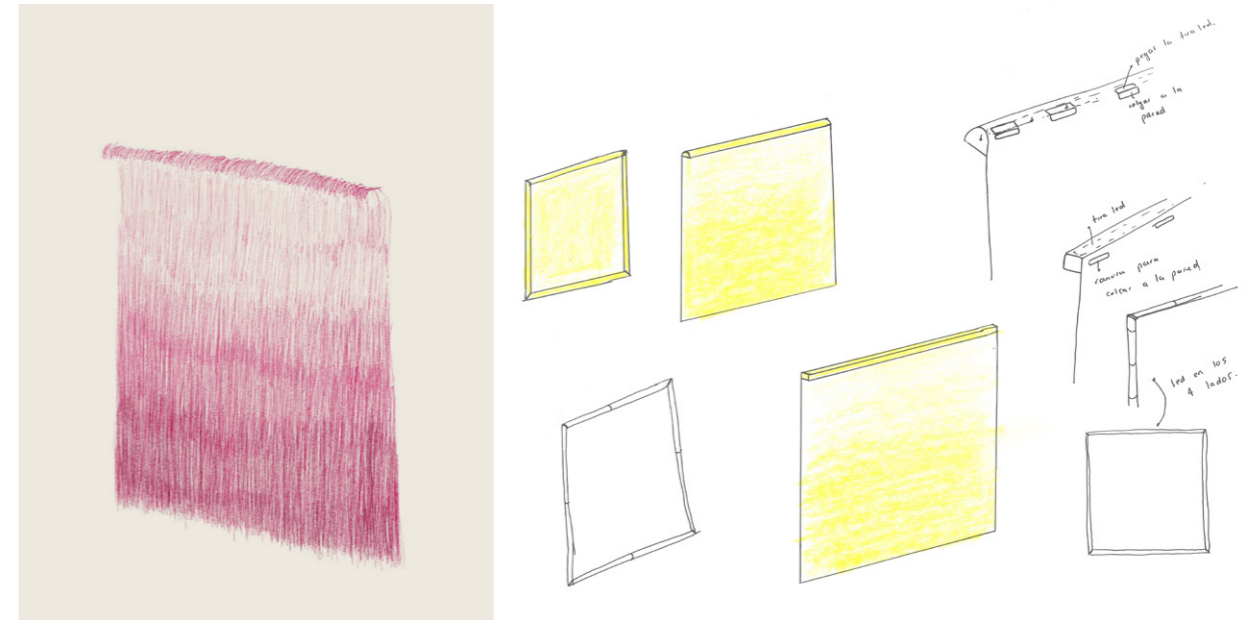

Constructed from thin planes of vertical sheet steel and using an integrated LED light with inline step dimmer.



Inspired by Luis Barragán, Moisés Hernández' LBM Table Lamp is influenced by the Mexican architect's innovative use of geometry, colour and light.



LBM Corner Table Lamp | Cream white



LBM Table Lamp | Tomato red

Anagram

Design by Sam Weller

Developed for HAY by British designer Sam Weller, Anagram Table Lamp combines a strong personality with a robust construction. Inspired by the idea of creating a nostalgic yet functional lamp, Sam's experiments with juxtaposing perforated steel with sheet steel led him to explore different lighting effects. The result is a generously curved, glossy shade that sits atop two split anodised aluminium legs, with the contrasting elements updating the familiar lamp typology with an original and contemporary aesthetic. Anagram's solid presence and ambient downlight make it equally suitable as a desktop-based lamp, or as a supplementary light source placed on a sideboard or windowsill.

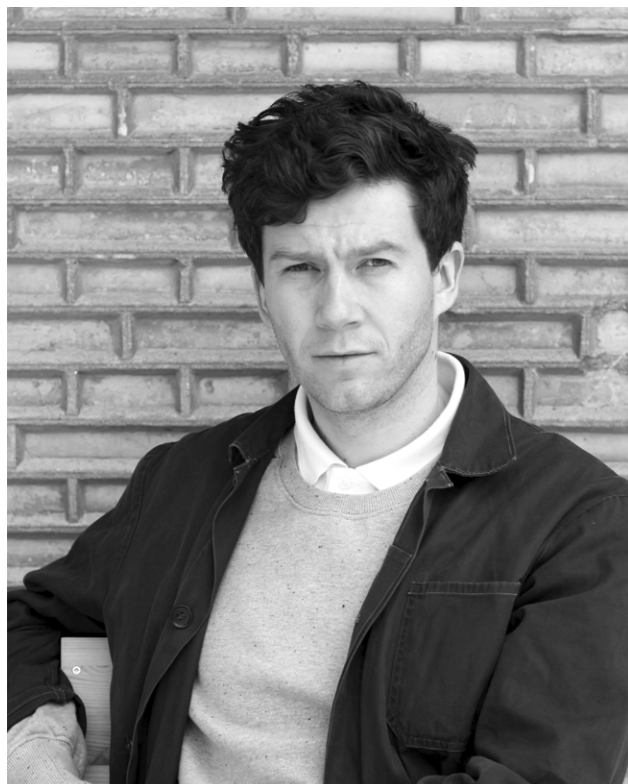

Sam Weller is a British designer, born with a background in Industrial Design and Engineering. Sam's design work aims to be timeless and honest, focusing on a pared-back aesthetic that reflects a product's material selection and function.



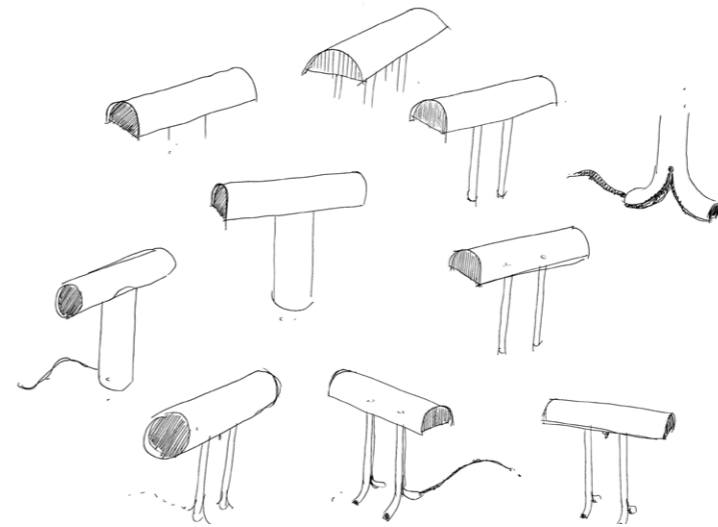

Anagram features a generously curved, glossy shade that sits atop two split anodised aluminium legs.



Inspired by the curves and forms of the Barbican in central London, Anagram's solid construction and generously rounded shade echo some of the architecture.



Anagram Table Lamp | Charred orange



Anagram Table Lamp | Rice

Apollo Design by STUDIO 0405

Designed by STUDIO 0405, the Apollo Lamp series is a collection of elegant table, ceiling and wall lamps with a distinctive, organic expression. Comprising the Apollo Table Lamp Shade, Apollo Portable Lamp, Apollo Chandelier, and Apollo Wall Sconce, all designs have mouth-blown shades in opal glass and offer a contemporary interpretation of a classic lamp archetype. The opal glass provides an ambient glow that adds warmth and atmosphere to its surroundings, making the lamps suitable for using in a variety of private and public settings.



Nikolaj Lorentz Mentze is a Danish designer and the owner of Copenhagen-based architecture and design firm STUDIO 0405.





Apollo Chandelier 745 | 6 Arm



Apollo Chandelier 1065 | 12 Arm



Apollo Wall Sconce



Apollo Table Lamp Shade

Factor Linear

Design by Dimitri Bähler

Designed by Swiss designer Dimitri Bähler, Factor Linear Suspension is an innovative lamp series with a rotatable tubular design. The 360-degree movement and height-adjustable linear construction enables users to create a flexible and personalised lit environment with either direct or indirect light. Easily assembled, it offers a simple plug-and-play lighting solution that requires no tools for assembly and adjustment. Made from extruded aluminium, the lamp features a dimmable integrated LED light source and is available in different colour options in different finishes. Factor is available in two variants depending on the user's needs – a warmer, more ambient light output – and another providing a cooler, more task-oriented lighting.



Dimitri Bähler is a Swiss designer who lives and works in Biel, Switzerland. His work is directed by his own sensitivity to the power of objects, and can often appear spontaneous, yet is underpinned by vigorous research.



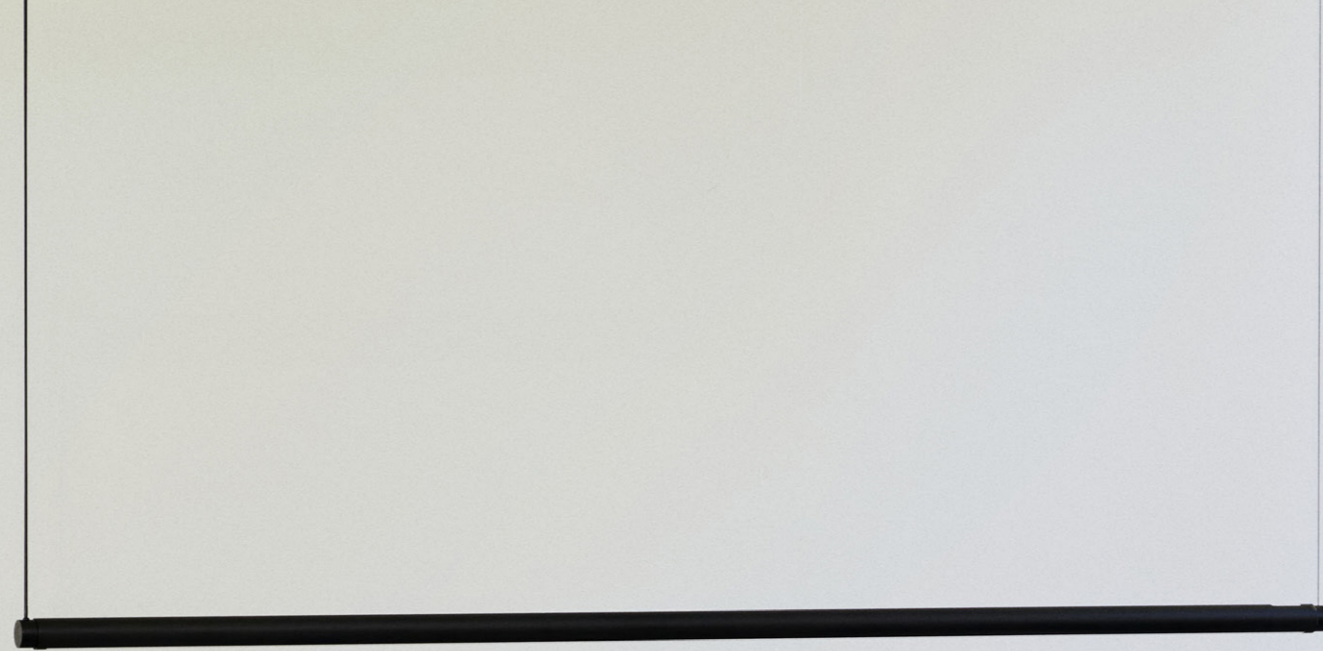

Factor Linear Suspension Lamp | Soft black



Factor Linear Suspension Lamp | Clear anodised

Paper Cube

Design by Bertjan Pot

Designed for HAY by Bertjan Pot, Paper Cube is a series of elegant and functional cubed lamps. The flat-packed design was inspired by Pot's fascination with the mechanics of constructing folded paper ornaments. The translucent cubed shade is closed on all four sides, fully encapsulating the light source and creating a soft ambient glow. Available in table and floor lamp variants, Paper Cube's clean design and warm, atmospheric light make it suitable for a variety of rooms at home, as well as restaurants, cafés and other public spaces.



Bertjan Pot is a Dutch designer working from his design studio in Rotterdam. His work reflects his curiosity for materials, with the starting point of most products arising from material research.





Paper Cube Lamp comes as a floor lamp and a table lamp, making it suitable for many different applications and environments.

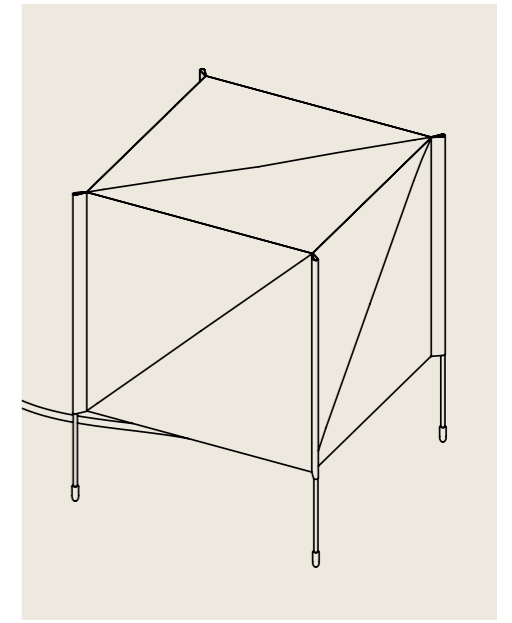

Inspired by Bertjan Pot's fascination with the mechanics of folded paper, Paper Cube Lamp has a simple yet innovative knock-down design.



The knock-down construction is easy to assemble, comprising folded recycled PET, and four wooden legs.



Paper Cube Table Lamp

Common

Fusing simple design language with a classic archetype, the Common Table and Floor Lamp series comprises a classic rice paper lantern design atop a slim stem and base. Designed as two separate elements that can be used apart or together, they form a harmonious pair, with the airy paper shade complementing the minimalist base perfectly. The lamp base is available as a table and floor variant, which supports the shade to create a soft glow that adds warmth and atmosphere to any space in the home.





Paper Shade for Common Lamp Base | Peach



Common Table & Floor Lamp

Common Cord Set Design by HAY

The Common Cord Set is a versatile cord set with components in matching colours. Available in two variants – for pendants and table lamps – the set is compatible with numerous HAY shades and can also be used alone with an E27 or E26 bulb. Both models are available in numerous colour options to create a functional and colourful lighting solution. Please note that bulbs are not included.



Common Table Cord Set



Common Pendant Cord Set



Common Pendant Cord Set

Arcs

Design by Muller Van Severen

Created for HAY by Belgian duo Muller Van Severen, Arcs reflects the designers' love of showcasing materials by focusing on simple, elemental shapes and the intensity of colour in an object. Arcs is a series of lighting designs formed from a continuous chain of curved arches that form a single element, using spatial volume to create a scalloped silhouette. Arcs is made from steel and comes in a choice of vibrant colours or with a mirror surface that reflects and magnifies the natural light. The different variants and mounting solutions give Arcs a versatile quality that makes it easy to integrate in most interior spaces.



Muller Van Severen was founded in 2011 by Belgian artist duo Fien Muller and Hannes Van Severen. The couple is inspired by sculpturally interesting furniture objects, and their work sits somewhere between design and art, drawing on their passion for architecture and materials.





A shared love of colour and materials is often the inspiration behind many of Muller Van Severen's designs.



Formed from a continuous chain of curved arches that form a single element, the Arcs Shade creates a spatial volume that plays with light and shape.





Arcs Shade | Sea green



Arcs Wall Sconce | Auburn red



Arcs Shade | Mirror



Arcs Shade | Cobalt blue

Slant Design by BRANCH

Slant is the result of a collaborative project between HAY and BRANCH – a design team comprising Japanese Tsunao Nagasaki together with graduates and students of Tama Art University's Department of Integrated Design, where he used to teach. Inspired by the power of shapes and how they impact their surroundings, the Slant Lamp features a bold graphic aesthetic that takes possession of the space it occupies. Comprising a simple, slanted cylindrical form with a weighted base to keep the angle perfectly balanced, all components are concealed within to retain the clean, elemental silhouette. Slant's sculptural design and functional, directional light make it suitable for a variety of home and office settings.



BRANCH is a creative unit that explores the relationship between the world, people and objects from the multiple perspectives of art, science and design. BRANCH is based in the Department of Integrated Design at Tama Art University in Japan.





Branch design team comprises Tsunao Nagasaki, long with graduates and current students at Tama Art University's Department of Integrated Design.



A cast iron weight creates stability in the base, whilst ensuring the tilted angle remains perfectly balanced.



The team decided to scale the lamp up from the original design and create more of a statement piece.



Slant Table Lamp | Khaki green



Slant Table Lamp | Soft black

Pao Design by Naoto Fukasawa

The Pao collection of lamps is an exciting collaboration with established Japanese designer Naoto Fukasawa. The Pao lamps draw on Fukasawa's "super normal" aesthetic of beautiful simplicity, everyday objects that draw on design values existing in the natural world. The inspiration for the form of these lamps came from a trip to Mongolia, where traditional nomadic tents, referred to locally as a 'Yurt' or in Japanese 'Pao', illuminated the landscape at night. Fukasawa was drawn to the glowing shape, which suggested comfort and warmth and the safety of "home," and represented a universal symbol he felt every person would find familiar in an intuitive way.



Japanese designer Naoto Fukasawa established NAOTO FUKASAWA DESIGN in 2003. His designs are known for their ability to access and communicate the true essence of an object.





The table lamp is made in opal glass, while the pendants are available in opal glass or steel with a high-gloss finish in different sizes and colours.



Named after the soft, glowing shape of traditional Mongolian Pao tents illuminated at night-time.





Pao Portable Lamp | Red



Pao Portable Lamp | Cream white



Pao Glass Floor Lamp | White



Pao Glass Table Lamp 350 | White



Pao Steel Pendant 470 | Cream white



Pao Portable Lamp | Cool grey

Matin

Design by Inga Sempé

Designed by Inga Sempé, the Matin lamp series offers a contemporary yet poetic design, with a construction that combines visual delicacy with physical robustness. Available in table, floor, wall and flush mounted variants, it combines steel or polished brass hardware with a pleated cotton shade in various size and colour options. The different models offer specific lighting solutions for all kinds of rooms and settings.



French designer Inga Sempé was inspired by ribbon shops in Paris to create a vast array of appealing colours for the shade.





The wall lamp has an adjustable head that can easily be angled to direct light up and down.

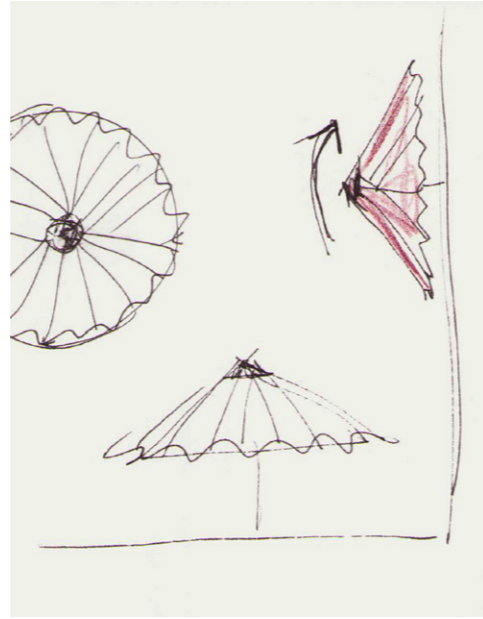

Matin comes flat-packed and is easy to assemble. The light source is an integrated LED.



Inga Sempé's drawings of Matin.





Matin Table Lamp 300 | Placid blue shade | Mirror plated steel base



Matin Pendant 500 | Peach

HAY x Liberty Matin

Featuring Liberty's distinctive floral print on the Matin Shade's classic pleated construction, the Liberty Matin Shade brings together two iconic designs in a poetic and timeless design. The shade's delicate yet contemporary expression brings an inviting atmosphere to most rooms in the home. The shade comes in different sizes and selected Liberty prints that all fit Inga Sempé's Matin Table Lamp, Flush Mount Lamp, Wall Lamp, and Pendant.







Matin Table Lamp 300 x Liberty | Cherry drop | Brass base

PC Design by Pierre Charpin

Pierre Charpin's PC lamp series is a family of refined and precisely engineered multifunctional lamps, featuring a variety of designs and functions. The collection includes variants with single- and double arms, as well as free-standing, desk, clamp, suspended, and wall-mounted lights, as well as a portable outdoor model, the PC Portable. Common to all designs is the designer's intention to keep the object as visually simple as possible, making sure technical components are kept out of view.



Paris-based designer Pierre Charpin's research on form and color characterise his work and can be seen in both, limited edition products and industrial products like the PC lamp.





The PC Portable provides up to 10 hours of light, and is perfect for outdoor as well as indoor use.

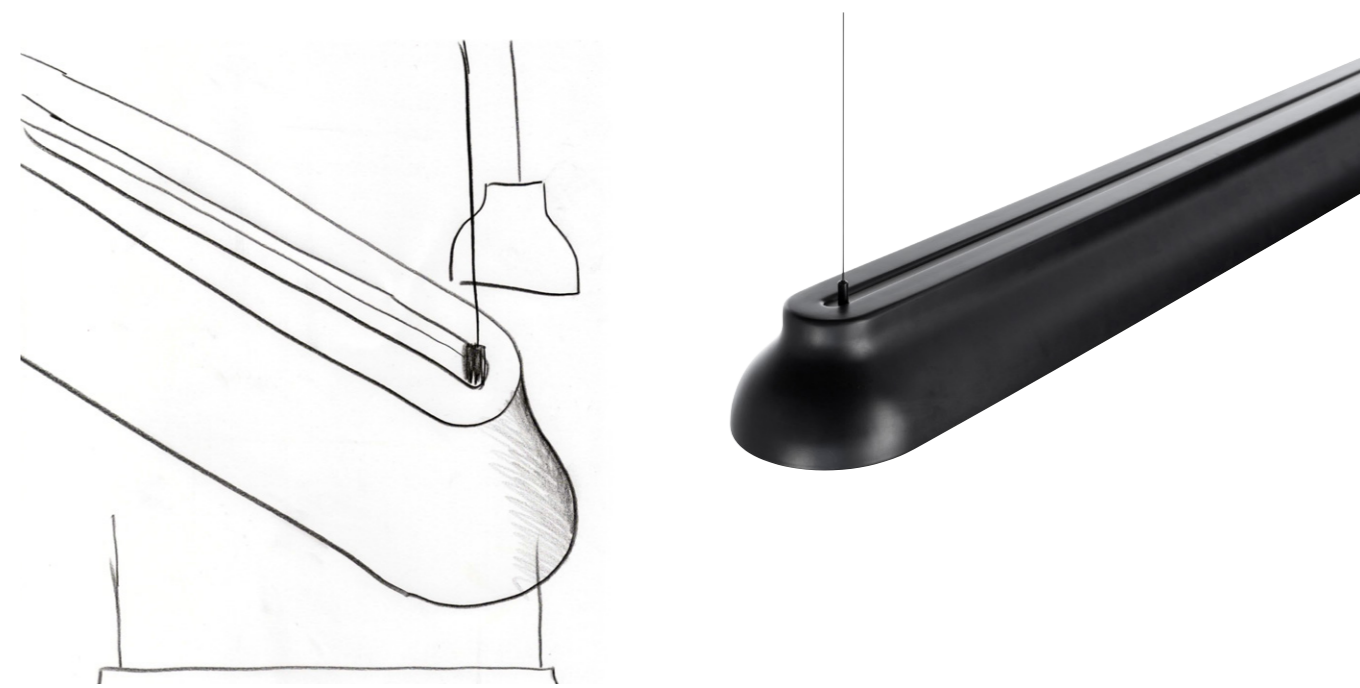

All of the lights in the iconic PC Lamp series share the line's signature tulip-shaped shade, and easily integrate into any environment.





PC Double Arm with table base | Soft black



PC Table Lamp S | Aluminium



PC Pendant S | Emerald green



PC Pendant L | Soft black



PC Portable Lamp | Cool grey & Soft yellow

Bonbon

Design by Ana Kraš

Inspired by her drawings, Ana Kraš' woven Bonbon Shades are produced using an original technique to create textured, one-of-a-kind pieces. Every shade is hand woven with nylon-wool yarn around a powder-coated steel frame, resulting in individual lampshades that vary slightly in their appearance and surface aesthetic. Bonbon is available either as a table/floor lamp or as a pendant, depending on the chosen cord set, but it stands on its own as a powerful decorative object even when the bulb is not switched on.



Ana Kraš is based between Paris and New York, and she works on projects in design, art, photography and fashion. Ana was born in Belgrade, Serbia, where she graduated from the University of Applied Arts.





Ana Kraš' Bonbon Shades are produced using an original technique to create textured, one-of-a-kind pieces.



Bonbon is a compelling artwork or design object.





Bonbon Shade 310 | Petit Bleu



Bonbon Shade 380 | Ice cream

Nelson Bubble For Herman Miller, available from HAY Design by George Nelson

Designed by pioneering American designer George Nelson in 1947, the Bubble Lamp represents an iconic moment in the history of design. Produced using a technique that was extremely innovative at the time, these elegant, floating orbs are lightweight and versatile. They are available from HAY in both pendant and wall-lamp styles and an assortment of sizes and shapes, enabling our customers to enjoy the soft glow of Nelson's revolutionary design in their own homes.



George Nelson was one of the most influential figures in the crucial early period of modern design. Courtesy Hermann Miller inc.



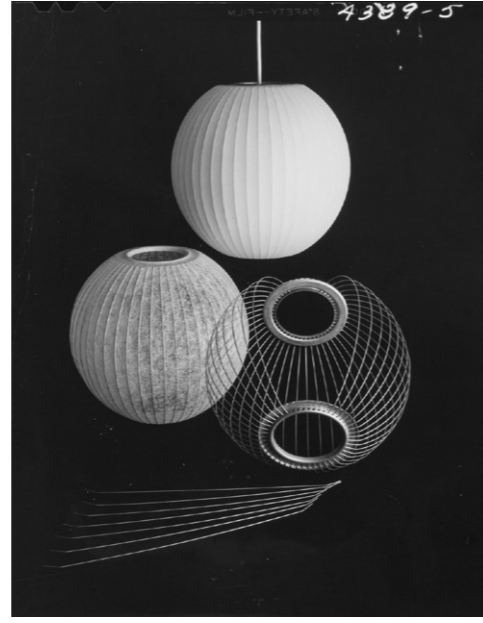

Designed by pioneering American designer George Nelson in 1947, the Bubble Lamp signaled a revolution in the Modernist lighting industry.



Photo by Leslie Schwartz, © 2013 Eames Office LLC (eamesoffice.com). All rights reserved.

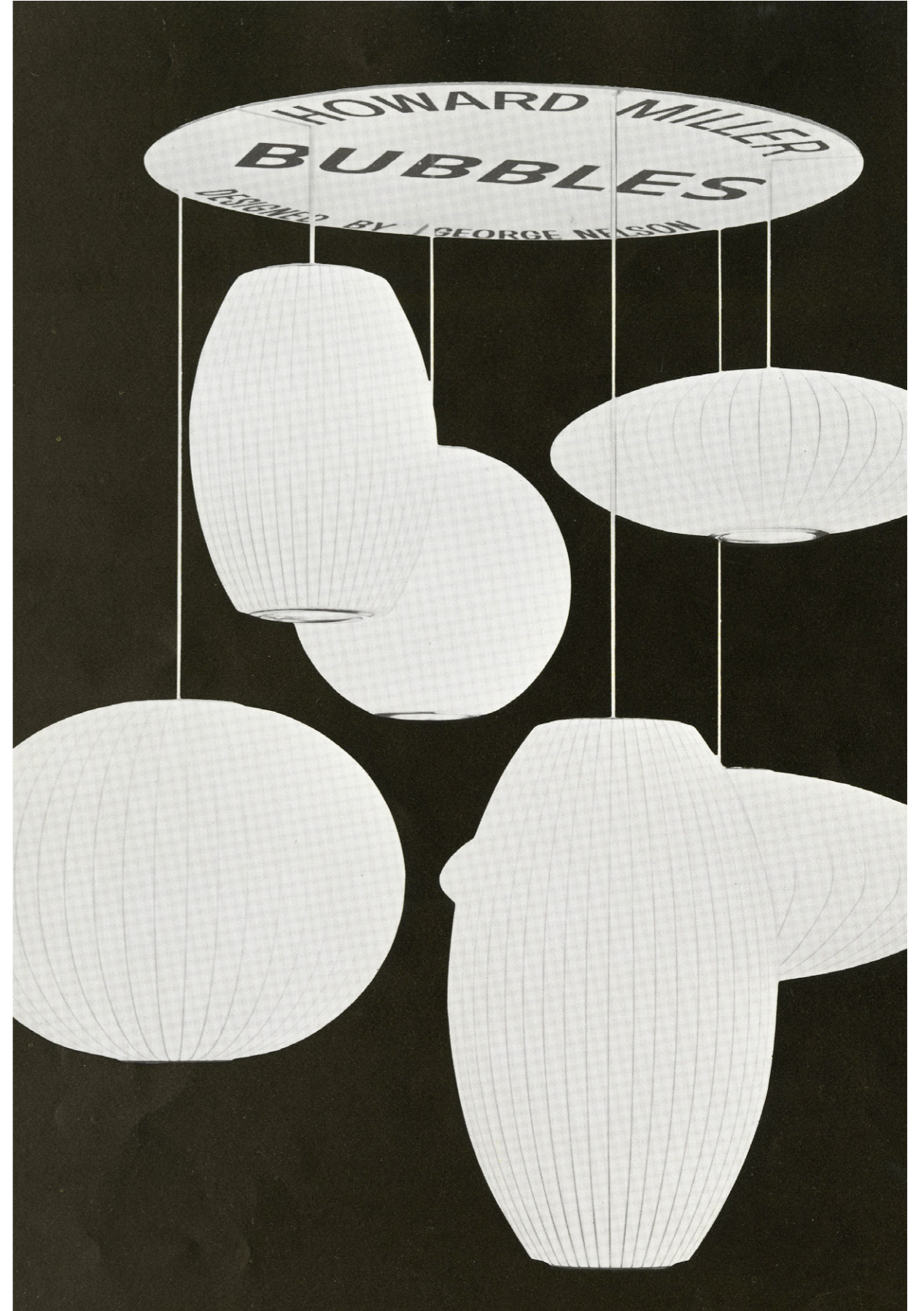

George Nelson, Courtesy Hermann Miller inc.



Nelson Roll Bubble Pendant



Nelson Angled Sphere Bubble Pendant | M



Nelson Saucer Bubble Pendant

Fifty-Fifty

Design by Sam Weller

Designed by Sam Weller and named Fifty-Fifty after a counterweight system that creates equilibrium between its two parts, this lamp makes clear references to physics and engineering. Configurable aluminium components minimise the overall complexity of the design and manufacturing process, transforming its joints and mechanisms into distinctive design features that are consistent throughout the entire series. The single cantilever arm is easy to tilt and pivot with one hand, featuring a touch-sensitive dimmer switch. The collection comprises table and floor lamps with weighted bases in large and small sizes.

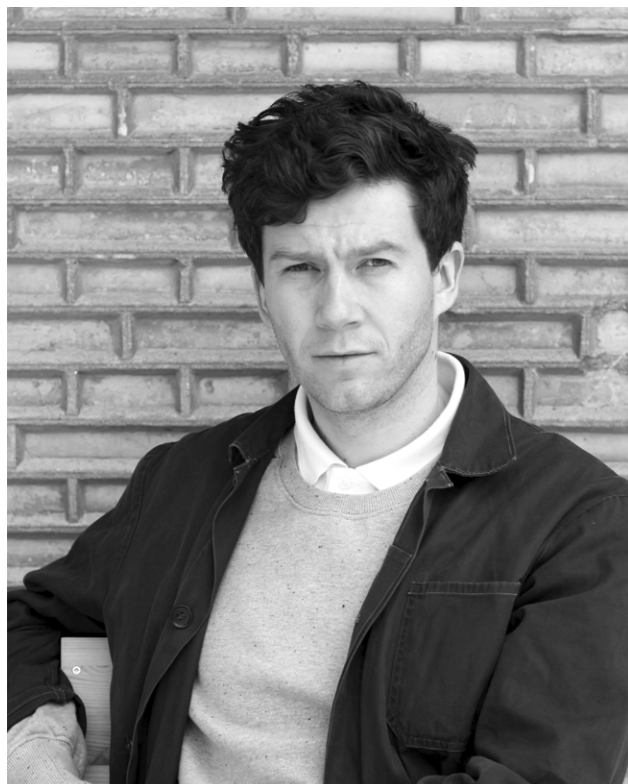

Sam Weller is a British designer, born with a background in Industrial Design and Engineering. Sam's design work aims to be timeless and honest, focusing on a pared-back aesthetic that reflects a product's material selection and function.





Fifty-Fifty Mini Table Lamp | Soft black



Fifty-Fifty Floor Lamp | Soft black

Marselis

Design by kaschkasch

Inspired by the bent tubing around local Danish street signs, design duo kaschkasch has created a family of table and floor lamps sharing the same arched silhouette. The light source comes from a tilting circular disc, which can be adjusted to create both an indirect ambient and a direct task-light beam. The lamp body is crafted from powder-coated, die-cast aluminium and steel, and the light source is an opalescent, injection-moulded polycarbonate lens that conceals a flat panel of light. Both lamp designs are available in different colours and are suitable for a variety of private and corporate settings.



Design studio kaschkasch was founded in 2011 by the two Germans Florian Kallus and Sebastian Schneider. The duo works in furniture, lighting design and art direction for several national and international clients.





kaschkasch was inspired by the bent tubing around street signs in their creation of the Marselis lamp.



Marselis Floor Lamp | Soft black



Marselis Floor Lamp | Ash grey

Turn On Design by Joel Hoff

This beautifully unified piece of design, produced in aluminium and opal glass, is made at human scale, effortlessly simple and pleasing to touch. The base is a faceted cylinder that works as both the light switch and the stem, which holds the spherical glass diffuser in place. Turning the base in a clockwise direction clicks the LED light on, with further rotation increasing the lumen output. Integrating movement into the design allows the user to intuitively brighten or dim the light. The base comes in four anodised finishes: black, aluminium, orange, and green.



Joel Hoff is an English designer working from his studio in London. He focuses on designing products that last, aiming to inspire more responsible consumers to own fewer items of greater quality.





Turn on | Aluminium



Turn On | Green

Noc

Design by SMITHMATTHIAS

The Noc Lamp series is a family of adaptable lights made from die-cast aluminium with a faceted shade and a smooth, powder-coated finish. It is available in three models: a universal clamp light called the Noc Clip, for use on tabletops, shelves, and headboards; the Noc Wall, featuring a cable and inline-rocker switch; and the Noc Wall Button, which conceals the cable inside the wall and features a touch-switch located on the base. This versatile series is designed for everyday use in both domestic and commercial settings.



London-based designers Jack Smith and Gemma Matthias take a responsible approach to their design work, which means that they design for the “long term.” They strive to create products that people can connect to, and that will be a pleasure to experience and use.





Noc Wall | Off white



Noc Wall | Dark grey

Cloche

Design by Lars Beller Fjetland

Designed by Lars Beller Fjetland, Cloche Table Lamp plays with visual imbalance to create a distinct shape. It features a domed shade, an angled, powder-coated aluminium arm, and an off-centre, cast-iron base. The shade is available in different colours and finishes, creating a decorative and directional lighting solution for a variety of office and home settings.



Norwegian designer Lars Beller Fjetland established his own studio in 2011. His approach to design is characterised by a fascination with nature, a desire to use disparate materials in combination, and a general sense of exploration.





Cloche | Mocca anodised



Cloche | Mint green anodised

30 Degrees Design by Johan Van Hengel

30 Degrees is a lightweight shade made of laminated oak veneer. The seamless surface is achieved by aligning the ends of semicircular veneer sheets at a 30-degree angle, so the inside cone and internal angle always maintain a 30-degree relationship. The layering of the conical veneer creates a solid shade that is opaque, characterized by its harmonious woodgrain pattern. Rich in tactility, the series express an organic yet elegant aesthetic.



Johan van Hengel is a Rotterdam-based product designer with a technical background in industrial design. In 2013, Johan launched his own studio with focus on furniture, lighting, and everyday objects.





30 Degrees | S



30 Degrees | L

Dimensions

Ceiling Lamps



PC Linear Lamp
W120 X D14 x H10 cm

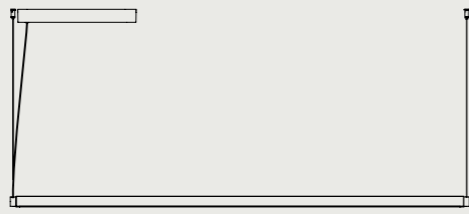

Factor Linear Suspension Lamp
W152 X D3,5 x H3,5 cm



Brim Pendant
Ø24,5 x H12,3 cm



PC Pendant
S | Ø25 x H14,5 cm



PC Pendant
M | Ø40 x H20,5 cm

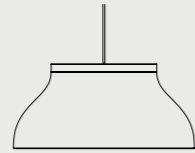

PC Pendant
L | Ø60 x H28 cm

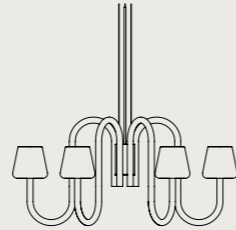

Apollo Chandelier 745
Ø74,5 x H36 cm



Pao Steel Pendant
230 | Ø23 x H10 cm

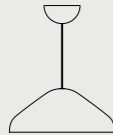

Pao Steel Pendant
350 | Ø35 x H14,50 cm

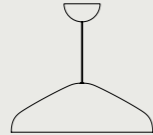

Pao Steel Pendant
470 | Ø47 x H16,25 cm

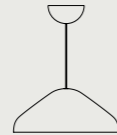

Pao Glass Pendant
350 | Ø35 x H14,50 cm

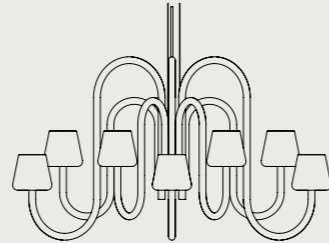

Apollo Chandelier 1065
Ø106,5 x H54 cm



Nelson Bubble Ball Crisscross Pendant
S | Ø32,5 X H30,5 cm



Nelson Bubble Ball Crisscross Pendant
M | Ø48,5 X H39,5 cm



Nelson Bubble Cigar Crisscross Pendant
S | Ø26,5 X H35,5 cm



Nelson Bubble Cigar Crisscross Pendant
M | Ø33 X H53,5 cm



Nelson Bubble Pear Crisscross Pendant
S | Ø33 X H32 cm



Nelson Bubble Pear Crisscross Pendant
M | Ø43 X H48,5 cm



Nelson Bubble Saucer Crisscross Pendant
S | Ø44,5 X H15 cm



Nelson Bubble Saucer Crisscross Pendant
M | Ø63,5 X H24 cm



Nelson Bubble Cigar Pendant
XL | Ø47,5 X H127 cm



Nelson Bubble Cigar Pendant
S | Ø26,5 X H35,5 cm

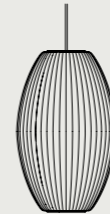

Nelson Bubble Cigar Pendant
M | Ø33 X H53 cm



Nelson Bubble Cigar Pendant
L | Ø38 X 84 cm



Nelson Bubble Ball Pendant
S | Ø32,5 X H30,5 cm



Nelson Bubble Ball Pendant
M | Ø48,5 X H39,5 cm

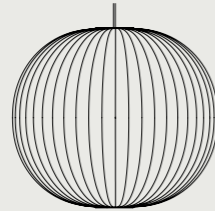

Nelson Bubble Ball Pendant
L | Ø68 X H59,5 cm



Nelson Bubble Lantern Pendant
S | Ø28 X H 26,5 cm



Nelson Bubble Propeller Pendant
M | Ø52 X H38 cm



Nelson Bubble Pear Pendant
S | Ø33 X H32 cm

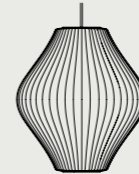

Nelson Bubble Pear Pendant
M | Ø43 X H48 cm



Nelson Bubble Apple Pendant
M | Ø53,5 X H37 cm

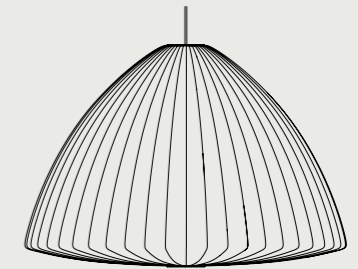

Nelson Bubble Bell Pendant
XL | Ø106,5 X H73,5 cm

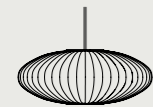

Nelson Bubble Saucer Pendant
S | Ø44,5 X H18 cm

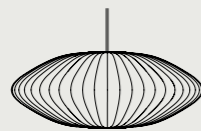

Nelson Bubble Saucer Pendant
M | Ø63,5 X H25,5 cm

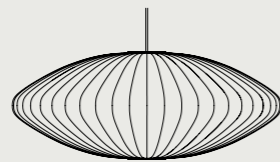

Nelson Bubble Saucer Pendant
L | Ø89 X H35,5 cm

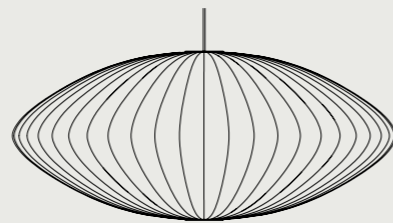

Nelson Bubble Saucer Pendant
XL | Ø127 X H56 cm



Nelson Bubble Angled Sphere
S | Ø35,5 X H24 cm



Nelson Bubble Angled Sphere
M | Ø49,5 X H38,5 cm



Nelson Bubble Angled Sphere
L | Ø71 X H56 cm

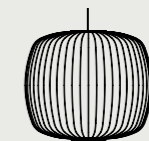

Nelson Bubble Roll
M | Ø42 X H39 cm

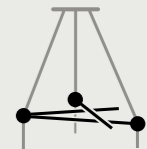

Nelson Fixture For Triple Bubble Lamp
Ø105 cm

Dimensions

Ceiling Lamps



Matin Flush Mount
380 | W38 X D38 x H16 cm



Matin Flush Mount
500 | W50 X D50 x H20 cm



HAY x Liberty
Matin Flush Mount
380 | W38 X D38 x H16 cm



Matin Pendant
300 | Ø30 X H11,5 cm

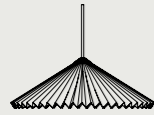

Matin Pendant
380 | Ø38 X H14 cm

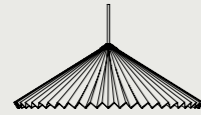

Matin Pendant
500 | Ø50 X H18 cm



HAY x Liberty
Matin Pendant
300 | Ø30 X H11,5 cm



HAY x Liberty
Matin Pendant
380 | Ø38 X H14 cm

Wall Lamps



Arcs
Wall Switch
W17 x D13 x H25 cm



Arcs
Wall Sconce
W17 x D13 x H25 cm



Matin Wall Lamp
300 | W30 X D25 x H30 cm



Matin Wall Lamp
380 | W38 X D25 x H38 cm



HAY x Liberty
Matin Wall Lamp
300 | W30 X D25 x H30 cm



HAY x Liberty
Matin Wall Lamp
380 | W38 X D25 x H38 cm

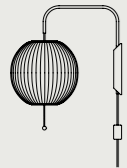

Nelson Ball
Wall Sconce Cabled
S | Shade Ø30,35 X H30,5 cm
Total D53,5 cm

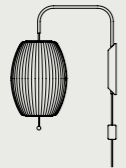

Nelson Cigar
Wall Sconce Cabled
S | Shade Ø26,5 X H35,5 cm
Total D50,5 cm

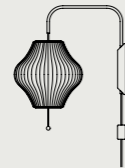

Nelson Pear
Wall Sconce Cabled
S | Shade Ø33 x H32 cm
Total D53 cm



Nelson Saucer
Wall Sconce Cabled
S | Shade Ø44,5 X H18 cm
Total D59 cm



Ono
Flush Mount
200 | Ø20 x D13,5 cm



Ono
Flush Mount
350 | Ø35 x D13,5 cm

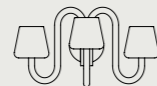

Apollo
Wall Sconce Lamp
W48 X D20 x H26,5 cm



Noc Wall
Button Lamp
W11,8 X D22 X H14 cm



Noc Wall
Lamp
W11 X D22 X H14 cm



Cupola
Wall Lamp
W11 x D60,7 x H13,4 cm

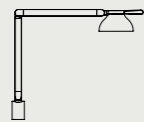

PC Double Arm
w. Wall Bracket
W14 X D55 X H45 cm

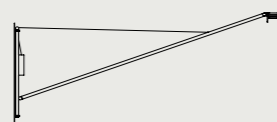

Fifty-Fifty
Wall Lamp
W7,5 X D187 X H67 cm

Table Lamps



Drome
Table Lamp
W31,5 x D22 x H22 cm

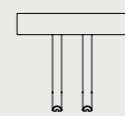

Anagram
Table Lamp
Ø36,5 x H32,5 cm



PC
Table Lamp
S | Ø25 x H33 cm



PC
Table Lamp
L | Ø40 x H50 cm



Slant
Table Lamp
W23,5 x D24,5 x H28 cm



Marselis
Table Lamp
W10 X D20 X H38 cm



Cloche
Table Lamp
W26 X D46 X H43 cm



LBM
Table Lamp
W22,5 x D10,5 x H22,5 cm



LBM
Corner
W25 x H25 cm



Turn On
Ø10 X H19,5 cm



Parade
Table Lamp
160 | W15,5 x
D15,5 x H16 cm



Parade
Table Lamp
240 | W15,5 x
D15,5 x H24 cm



Parade
Table Lamp
320 | W15,5 x
D15,5 x H32 cm

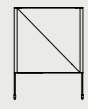

Paper Cube
Table Lamp
W21,5 x D21,5 x H30,5 cm



Matin
Table Lamp
300 | Ø30 x H38 cm



Matin
Table Lamp
380 | Ø38 x H52 cm



HAY x Liberty
Matin Table Lamp
300 | Ø30 x H38 cm



HAY x Liberty
Matin Table Lamp
380 | Ø38 x H52 cm



Common Table Lamp
Peach Shade
Ø44 x H67 cm

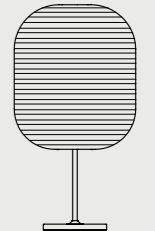

Common Table Lamp
Oblong Shade
Ø42 x H75 cm

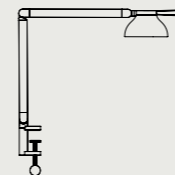

PC Double Arm
w. Clamp
W14 X D55 X H60,5 cm

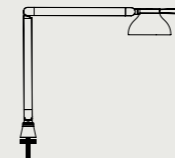

PC Double Arm
w. Table Insert
W14 X D55 X H42,5 cm

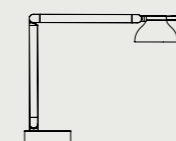

PC Double Arm
w. Table Base
W14 X D55 X H42 cm

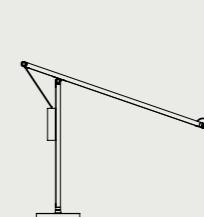

Fifty-Fifty
Mini Table Lamp
W16,5 X D65 X H45 cm

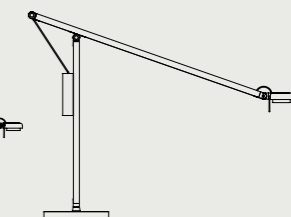

Fifty-Fifty
Table Lamp
W18,5 X D90 X H60 cm



Cupola
Desk Lamp
W16 x D31,8 x H40,8 cm



Apex
Table Lamp
W19 X D16 X H38 cm

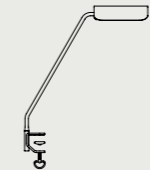

Apex
Desk Clip Lamp
W14 X D36,5 X H43 cm

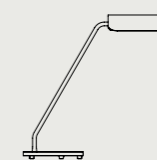

Apex
Desk Lamp
W16 X D39 X H38 cm

Dimensions

Clip Lamps



Cupola Clip Lamp
W11 x D14 x H29,5 cm



Apex Clip Lamp
W14 x H27,5 cm

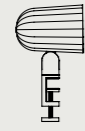

Noc Clip Lamp
W10 X D14 X H22 cm

Floor Lamps

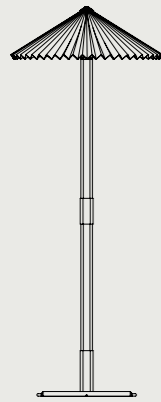

Matin
Floor Lamp
500 | Ø50 x H129 cm

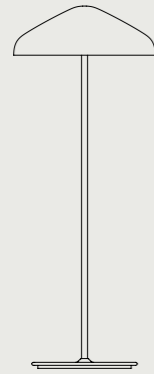

Pao Steel
Floor Lamp
470 | Ø47 x H120 cm

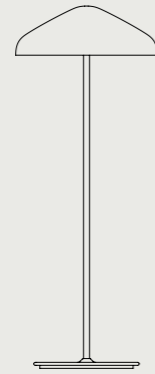

Pao Glass
Floor Lamp
470 | Ø47 x H120 cm



Common
Floor Lamp
Peach Shade
Ø44 x H155,5 cm



Common
Floor Lamp
Oblong Shade
Ø42 x H160,5 cm



Marselis
Floor Lamp
W17,5 X D21,2 X H126 cm

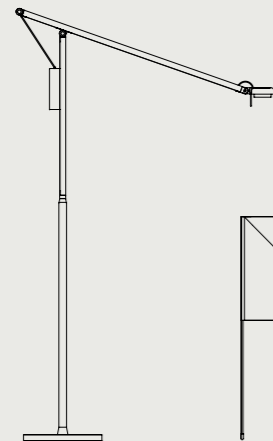

Fifty-Fifty
Floor Lamp
W25 X D90 X H135 cm

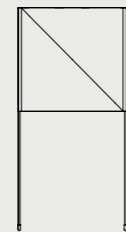

Paper Cube
Floor Lamp
W36 X D36 X H74 cm

Portable Lamps



Mousqueton
Portable Lamp
Ø19,5 x H30,5 cm



PC
Portable Lamp
Ø14 x H22 cm



Apollo
Portable Lamp
Ø12,5 x H22 cm



Pao
Portable Lamp
Ø23 X 23 cm

Lamp Shades



Arcs Shade
W20 x D20 x H30 cm

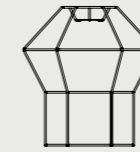

Bonbon Shade
310 | W32 X D32 x H38 cm

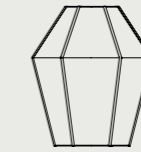

Bonbon Shade
320 | W32 X D32 x H38 cm

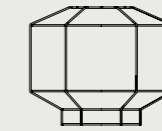

Bonbon Shade
380 | W38 X D38 x H32 cm

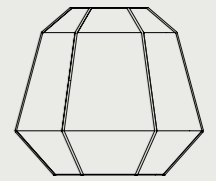

Bonbon Shade
500 | W50 X D50 x H46,6 cm

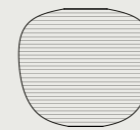

Paper Shade
for Common
Lamp Base
Peach
Ø42 x H39 cm



Paper Shade
for Common
Lamp Base
Oblong
Ø24 x H50 cm



30 Degrees
Shade
S | Ø24 x H17 cm



30 Degrees
Shade
M | Ø33,5 x H25 cm

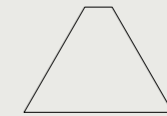

30 Degrees
Shade
L | Ø45 x H35 cm



Apollo Table
Lamp Shade
Ø25 x H38 cm

Cord Sets



Common
Pendant Cord Set
Ø12 cm
Cord length 400 cm



Common
Table Cord Set
Ø4,5 cm
Cord length 240 cm

