

- INSTRUCTION MANUAL -

PANDARINE

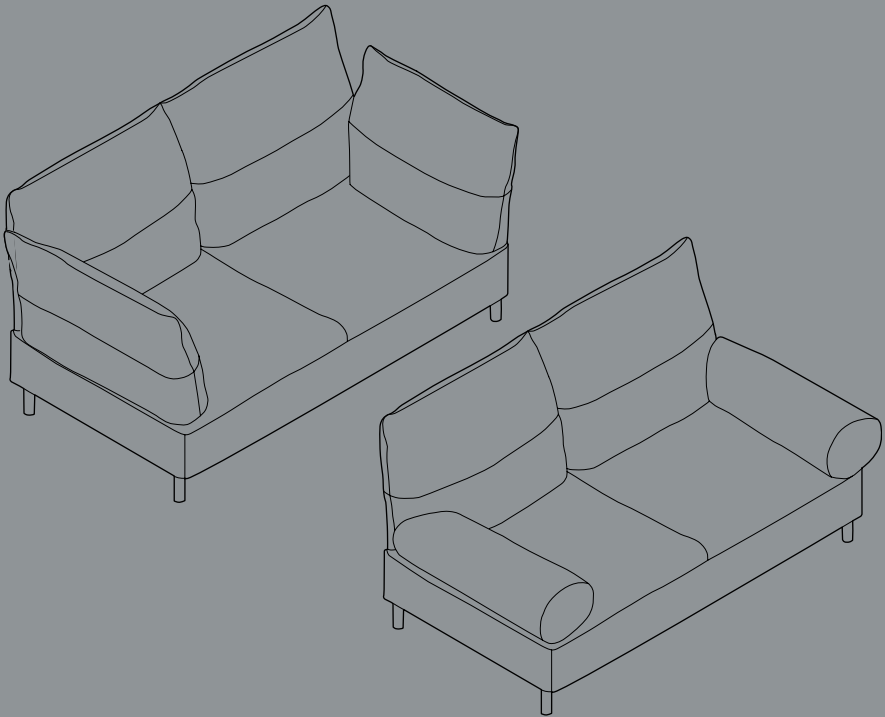

DESIGN BY INGA SEMPÉ

HAY

Inga Sempé's Pandarine fuses the luxurious comfort of a bed with the versatility of a modular sofa in an elegant and versatile design. The armrests come either in a cylindrical form, or with a reclining design that can be adjusted individually in the same way as the metal-hinged backrests. This gives Pandarine the ability to transform into a unified, mattress-like surface where the backrests serve as huge, soft pillows.

Constructed using a combination of Nozag springs, foam, and wadding, Pandarine is designed to provide exceptional comfort in any number of sitting or lying positions. Available in two- and three-seater versions with options for additional chaise longues and corner modules, its range of textiles and configurations give it great flexibility for use in a variety of private and public contexts.

CAUTION

With a little care you can prolong the life of your furniture. Follow the instructions for the materials of your specific product to make sure that it stays in the best shape for as long as possible.

The information below is only intended as a general guideline. For more information on how to remove specific stains, please enquire where you bought the furniture.

- / Always remove stains quickly before they can do any permanent damage to the furniture.
- / Avoid placing the furniture in direct sunlight or near a strong heat source to reduce changes. As wood is a natural material, it will change in colour and will patinate over time. HAY only uses top quality fabrics, but all fabrics fade and seams weaken when exposed to sunlight or strong heat.
- / General exposure to dust and dirt wears down the fabric. Regular cleaning is important in order to keep the upholstery looking its best and to prolong its life.
- / The upholstery is fixed and cannot be removed.
- / When you move your furniture, make sure you lift it rather than pulling or pushing it to avoid damaging the floor, legs and mountings.
- / Avoid improper use such as sitting on the back or armrests, or standing on the sofa.
- / Be careful not to scratch or damage the surface with sharp objects.
- / Smooth out creases and wrinkles with

your hand after use to even out the fabric and prevent seam lines from becoming skewed.

FABRICS

- / Vacuum the furniture regularly using the upholstery nozzle to remove dust and avoid fluff and pilling.
- / Straighten the fabric with your hands from time to time. Wrinkles in the fabric can be straightened using a steamer.
- / Soak up spilled liquids immediately with an absorbent napkin or cloth by dabbing gently towards the centre of the stain.
- / Never use concentrated detergents or bleach, ammonia, optical brighteners or soap intended for hard surfaces.
- / We do not recommend spot cleaning of individual marks and stains as this damages the fabric and causes colour loss.
- / On wool fabrics, most stains can be removed with lukewarm water on a clean lint-free cloth. If necessary, add a little neutral detergent. Avoid rubbing the material hard as this could result in loss of colour and damage the fabric. It may also be necessary to use a hairdryer to avoid leaving a water outline. If the stain persists, consult a specialist cleaner.

VELOUR

- / Vacuum the furniture regularly using the upholstery nozzle /or brushing with a soft clothes brush – always in the direction of the nap to remove dust and avoid fluff and pilling.

- / To rejuvenate velour and restore its pile, rub it with a well wrung, slightly damp cloth in the direction of the nap.
- / When you sit on velour fabric, you exert a pressure that forces the nap in different directions. Together with heat, rising air humidity, body moisture and the type of upholstery, this can cause these changes of direction to become fixed, creating a slight change in colour. This is a typical property of velour, and is neither a defect nor a sign of low quality. This effect can be removed by applying a damp (not wet) cloth and leaving it overnight, which will restore the pile to its original direction. The upholstered furniture should not be used until it is completely dry. If necessary, a hair dryer can be used at a low temperature setting.
- / The same result can be achieved by steaming or spraying distilled water at a distance of 20 cm from the fabric for a few seconds, before leaving overnight. Care should be taken not to spill large quantities of water on the fabric. It is advisable to treat the whole surface in order to avoid shading. This treatment can be repeated if necessary. After this treatment, the upholstered furniture must be completely dry before it can be used again. A hair dryer at a low temperature setting can be used. To restore the pile to its original direction, please brush with a soft brush.

ANILINE LEATHER

- / Aniline leather has no or only a light surface treatment to preserve the leather's natural surface and soft touch.

- / All natural markings, such as scars and insect bites, will be visible on aniline leather, which contributes to the leather's exclusive appearance.
- / This kind of leather is very susceptible to dirt, and over time it will patinate and become slightly darker.
- / Be careful not to scratch the leather.
- / Aniline leather is demanding to maintain, and we recommend that you keep a cleaner and care product suitable for this type of leather at hand. Using water may leave a permanent stain on the surface.
- / Do not use sharp objects, strong detergents or solvents on the leather.

SEMI ANILINE LEATHER

- / Semi-aniline leather is a full grain leather with a light top finish.
- / All natural markings, such as scars and insect bites, will be visible on the leather.
- / Vacuum regularly using the upholstery nozzle. Be careful not to scratch the leather.
- / To remove stains, use a clean, lint-free cloth to apply the lather from a solution of water and a neutral detergent or soap flakes or use a special leather care product. Remove soap residue immediately using a clean, dry cloth, and polish gently, using a soft cotton cloth. Avoid pressing liquid into the pores of the leather.
- / Apply a protective lotion two to four times annually to enhance the resistance of the material.

- / Do not use sharp objects, strong detergents or solvents on the leather.

PIGMENTED LEATHER

- / Pigmented leather is corrected leather with excellent durability.
- / Vacuum regularly using the upholstery nozzle. Be careful not to scratch the leather.
- / To remove stains, use a clean, lint-free cloth to apply the lather from a solution of water and a mild detergent, or soap flakes, or use a special leather care product. Remove soap residue immediately using a clean, dry cloth, and polish gently, using a soft cotton cloth. Avoid pressing liquid into the pores of the leather.
- / Apply a protective lotion two to four times annually to enhance the resistance of the material.
- / Do not use sharp objects, strong detergents or solvents on the leather.

OILED WOOD

- / Wipe with a clean, dry cloth. If the surface is dirty, wipe with a clean cloth wrung in water or in a solution of water and a neutral detergent or soap flakes. Remove any soap residue immediately using a clean, dry cloth.
- / Never use soft soap or solvents such as spirit, turpentine or acetone.
- / Avoid using scouring cream or scouring pads, as they may scratch the surface.
- / If the surface is scratched or appears matt, make sure to use an oil

hardening care product specifically designed to maintain oiled wooden surfaces.

- / Clean the furniture thoroughly (12 hours) before applying the oil to all surfaces. To ensure optimal absorbency, gently sand down the wood using fine-grit sandpaper (No. 180 or 240), always sanding in the direction of the grain. Apply the oil generously using a clean cloth or a sponge, always applying in the direction of the grain. Do not pour the oil directly on the surface.
- / When the surface is glistening, leave the oil on for around two hours until fully absorbed. Remove any excess oil with a clean lint-free cloth. Leave the furniture to dry overnight (min. 12 hours) and avoid placing anything on the surface before it is completely dry.
- / If the grain of the wood rises after oiling, gently sand down the wood using fine-grit sandpaper (No. 180 or 240), always sanding in the direction of the grain.
- / To optimally maintain the naturally beautiful appearance of the wood, we recommend you regularly treat the furniture's surface with oil whenever it appears dull, scratched or as needed.

STAINED WOOD

- / Wipe with a clean cloth wrung in water or in a solution of water and a neutral detergent. Remove soap residue immediately using a clean, dry cloth.
- / If the surface is scratched or appears matt, use a care product specifically suited to lacquered or stained wood.

- / Avoid using detergents containing silicone, as they seal the stain in and make subsequent repairs more difficult.
- / Avoid using scouring cream or scouring pads, as they may scratch the surface.

CHROMED STEEL

- / Wipe with a clean cloth wrung in water or in a solution of water and a neutral detergent. Remove soap residue immediately using a clean, dry cloth.
- / Avoid using scouring cream or scouring pads, as they may scratch the surface.
- / White spirit (mineral spirit) can be used to carefully remove stains from chromed surfaces.
- / Do not use solvents as they may have an adverse effect on the coating.
- / Never use acetic acid or citric acid.

- PARTS -

- ASSEMBLY -

Mount the legs **B** using the screws **D** and Allen key **E**.
The below diagram shows placement of legs, with the legs indicated by black dots.

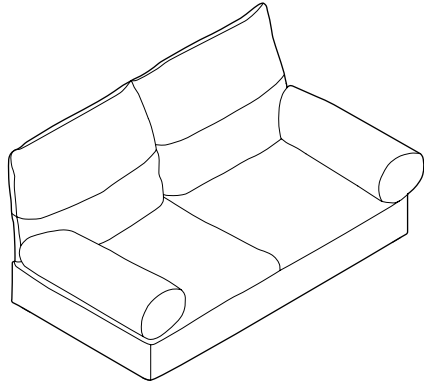

A Sofa modules

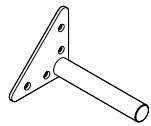

B Leg

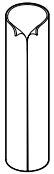

C Leg sleeve



D Screw



E Allen key

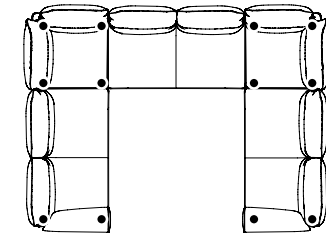
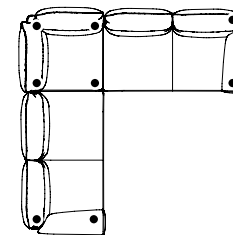
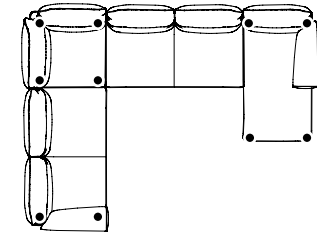
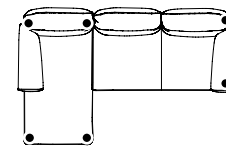
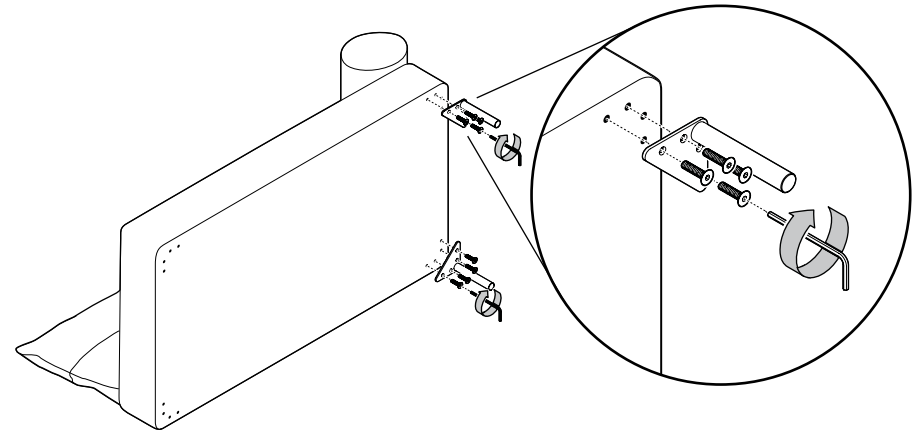

Examples of placements of legs.

- ASSEMBLY -

Mount the sleeve **B** by simply sliding it onto the leg. Make sure the seam is facing towards the middle of the sofa to minimise its visibility. If your sofa consists of several modules, assemble them by interlocking the two brackets together. Make sure to push the two parts of the sofa together while pushing down.

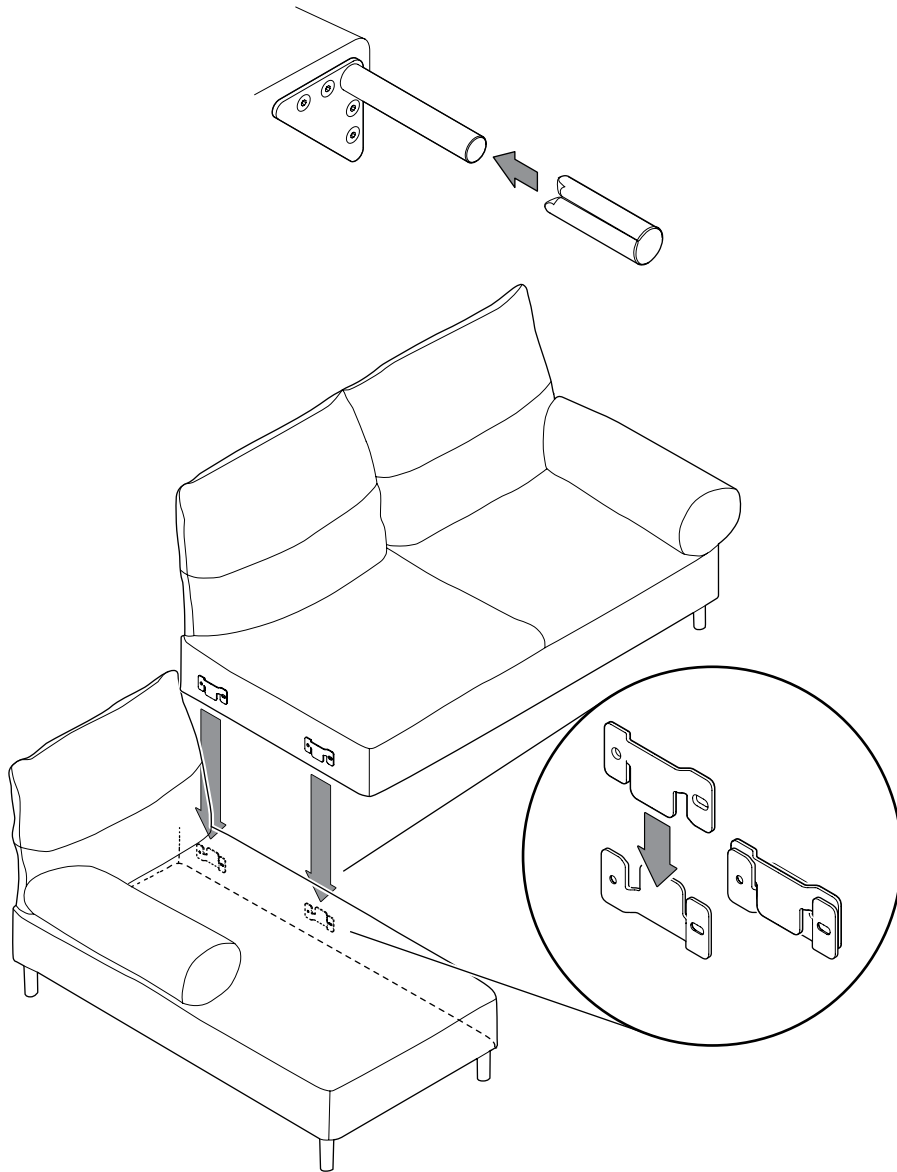

- MAINTENANCE -

Over time, your sofa will need some attention to ensure that the cushions remain plump and the seat cushion keeps its shape. To ensure that the cushion filling is spread evenly, follow these steps to plump the cushions. Repeat regularly when needed.

More information on your specific fabric is to be found under the Care and Maintenance section.

PLUMPING CUSHIONS

Start from the bottom of the cushions and pull your hands up, while applying pressure.

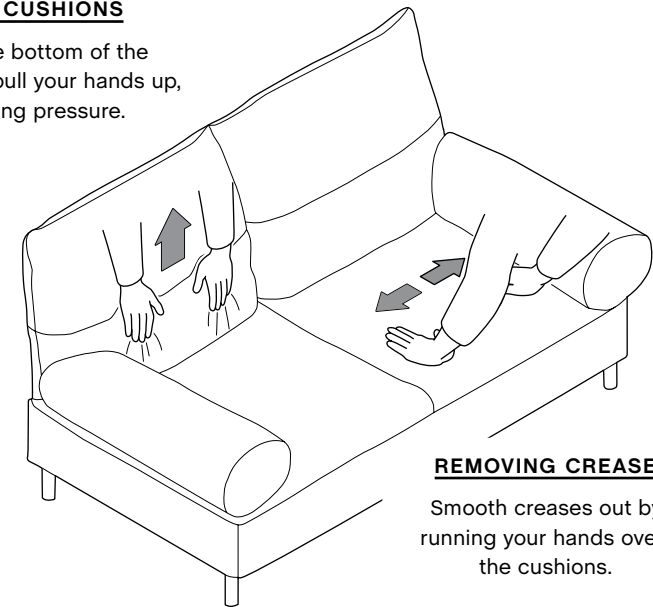

REMOVING CREASES

Smooth creases out by running your hands over the cushions.

- FUNCTION -

By pushing down on the backrest, you can tilt it backwards. To reset its position, simply lift it back up while holding one hand on the front of the cushion. This function is also available on reclining armrests.

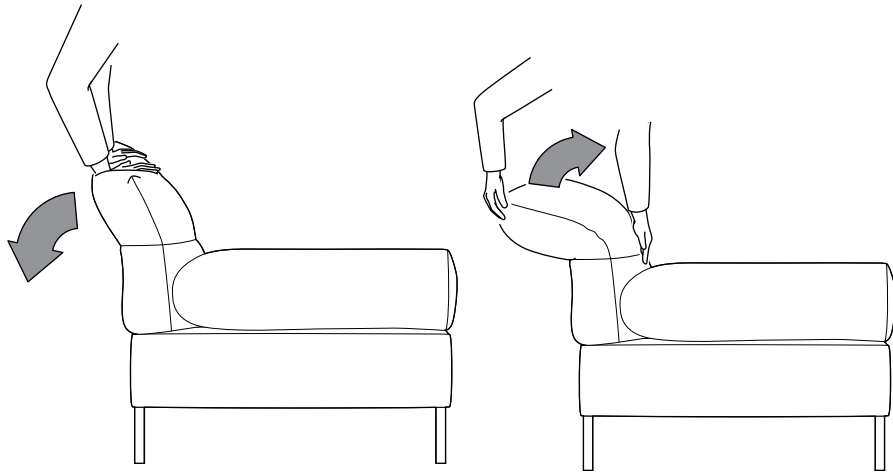

Backrest

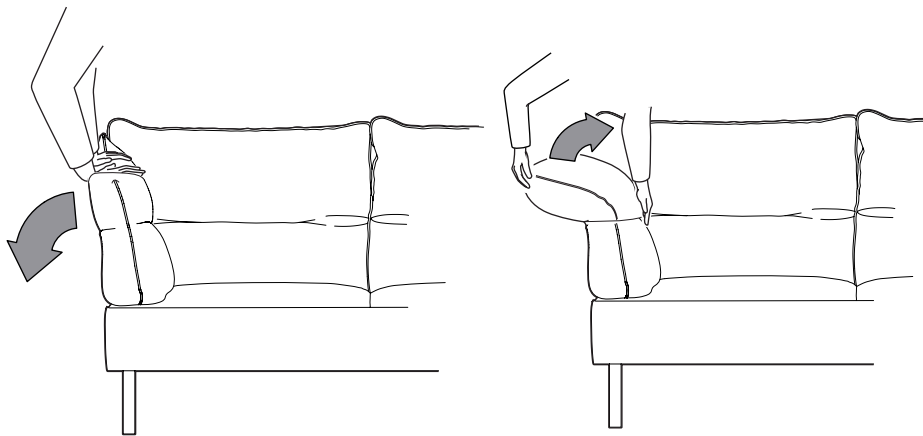

Armrest

Havnen 1 8700 Horsens Denmark
+45 4282 0282 / hay@hay.com

02/06/20

HAY