

viccarbe

Ace

Designed by Jean-Marie Massaud

Catalogue - EN



Jean-Marie Massaud

Jean-Marie Massaud was born in Toulouse (France) in 1966.

He graduated from Les Ateliers, Ecole Nationale Supérieure de Création Industrielle, in Paris, France, in 1990. He has since worked for various design studios in Asia and France. In 1994, he established his own studio in Paris, specialising in industrial and interior design for European and Japanese companies such as Yves Saint Laurent, Renault, Cappellini and Magis. At present, he develops, together with Daniel Pouzet, architectural projects for both public and private clients.

At the Ecole Nationale Supérieure des Arts Décoratifs in Paris, Massaud's classes present his contextual approach regarding the various facets of design, focusing on the individual as a quest for the essential. His work transmits magical and vital emotions.

ACE

The subtlety of a gesture

Armchair designed by Jean-Marie Massaud, 2007

“Today, more than ever, within the office space we are looking for small oases in which to take refuge. We want particular corners in which the “I” takes on as much relevance as possible.”

The last few months have made the concept of well-being particularly relevant. An ethereal idea, invaluable, immaterial in many cases. A minimum that allows us to face our day to day with concentration and stability.

Today, more than ever, within the office space we are looking for small oases in which to take refuge. We want particular corners in which the “I” takes on as much relevance as possible. They are places in which we simply seek to feel comfortable, safe, at certain times we may even be protected by a certain amount of privacy.

The Ace chair is one of those designs that are born with a

protective instinct, returning us to the most essential comfort. As a product, it will subtly attract our attention with a slightly wrinkled and friendly upholstery. It will welcome us and, ultimately, give us the space we need to reconnect.

In recent years, Jean Marie Massaud’s design has been incorporated into the work spaces of large multinationals such as Nike and Toyota. It was included in certain projects, as a space for informal and collaborative meetings. In other projects, it was also incorporated in an individual format: located inside private offices or rest areas, and set up as a place to go in search of a universe of one’s own. It’s time to regain a sense of well-being.

On this page, Ace armchair with wooden base and Burin Mini in black finish





Project: Vivood Landscape Hotel





Ace & Lounge

Transitional Spaces — We say goodbye to the so-called waiting areas to welcome the intermediate or transitional spaces. The essence is the same, probably even the arrangement of the furniture.

Project: VIVOOD Landscape Hotel, Alicante
Pictures: Ángel Segura





Project: Viccarbe Headquarters
Pictures: Javier Díez



Project: Teulada Concert Music Hall





Project: Parador Sutega, Spain
Pictures & Interiors: RGS Europe





Project: Teulada Concert Music Hall







Project: Private Residence
Pictures: Ángel Segura

On these pages, Ace armchair metal base in black with grey upholstered and red zip.





viccarbe

ACE LOUNGE CHAIR

ACAM | ACAM_TX

stained wooden base armchair | lacquered wooden base armchair

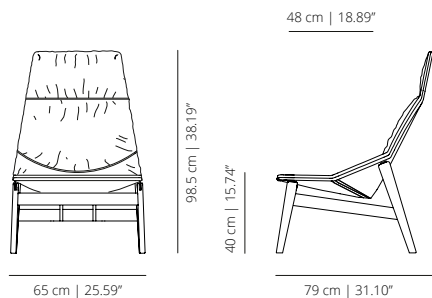

ACAMB | ACAMB_TX

stained wooden base armchair with arms | lacquered wooden base armchair with arms

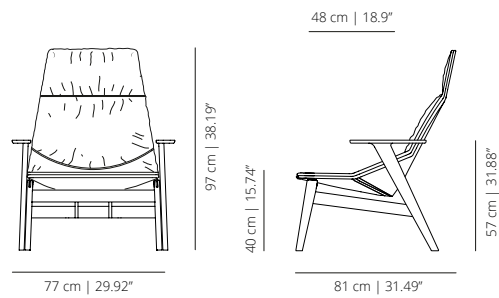

ACASOFT

metal base armchair

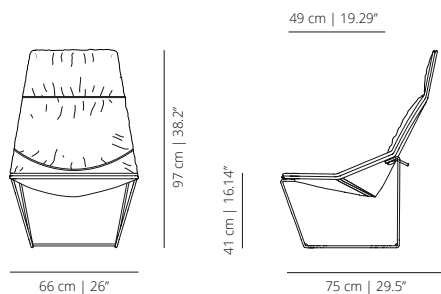

ACCESSORIES

ACARE

headrest

Accessory that adapts perfectly to the shape of the chair and the height of the user. It makes it possible to enhance comfort for situations that require prolonged sitting. Requires no installation. Available for the high chair in all fabrics of our collection.

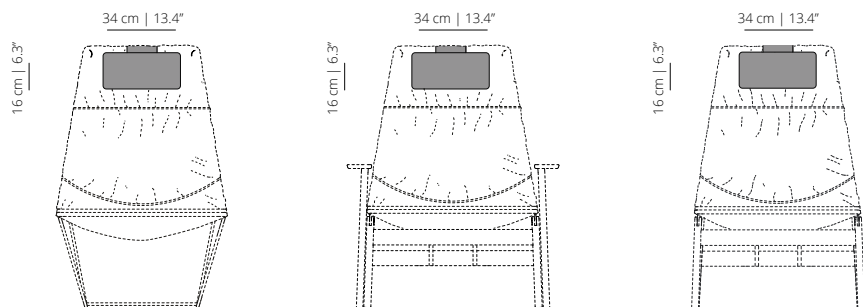

FINISHES

Upholstery

[Check upholstery samples](#)

STRUCTURE

Stained Wood



bleached
stained oak



matt
stained oak



cognac
stained oak



walnut
stained oak



ash
stained oak

STRUCTURE

Powder coated



white
RAL 9003



black
RAL 9005

ZIPPER



blue
RAL 5012



green
RAL 6029



red
RAL 3027



yellow
RAL 1016



black
RAL 9005

TECHNICAL INFO

Seat with inner steel structure covered in shape-holding expanded polyurethane foam of different thicknesses and polyester fibre. Removable upholstery on the front. Two-tone upholstery option in leather, fabric or combined. Upholstery available in fabric or leather.

Base options:

Wooden base – Base in solid oak wood stained with the finishes of our collection. Internal frame of calibrated steel tube powder coated in thermoreinforced polyester covered with shape-holding expanded polyurethane foam. Zip-around closure*. Plastic glides with or without felt**.

Metal base – Base of calibrated steel tube powder coated in thermoreinforced polyester in white and black. Internal frame of calibrated steel tube powder coated in thermoreinforced polyester covered with shape-holding expanded polyurethane foam. Zip-around closure*.

CERTIFICATIONS

ANSI/BIFMA X5.1:2011 and UNE 16139:13 vc 2015 (wooden base armchair), ANSI/BIFMA X5.4-2012 and UNE-EN 16139:2013 (metal base armchair)

**Zipper not removable. Perimeter zipper available in the following colours: blue RAL 5012, green RAL 6029, red RAL 3027, yellow RAL 1016 and black RAL 9005.*

***Available for the wooden base armchair, felt glides. If not indicated, the armchair will be produced with plastic glides.*

Let's talk

We want to help you find the best designs for your project. Get in touch and our team will get back to you as soon as possible.

+ CONTACT US

